

QUICK SELECTION / Selezione veloce

input speed (n₁) = 1400 min⁻¹

	Output Speed n ₂ [min ⁻¹]	Ratio i	Motor power P _{1M} [kW]	Output torque M _{2M} [Nm]	Service factor f.s.	Nominal power P _{1R} [kW]	Nominal torque M _{2R} [Nm]	Available B5 motor flanges				Available B14 motor flanges				Dynamic efficiency RD	Tooth Module [mm]	Ratios code
								-B	-C	-D	-E	-P	-Q	-R	-T			
								63	71	80	90	63	71	80	90			
IEC 90 - 80 - 71	47	29.9	0.75	113	1.6	1.20	182					C	C		74	2.6	01	
	37	37.7	0.75	141	1.3	0.97	182					C	C		73	2.0	02	
	30	47.1	0.75	169	1.2	0.91	206					C	C		70	3.2	03	
	25	56.6	0.75	185	1.1	0.83	206					C	C		64	2.7	04	
	19.8	70.7	0.55	162	1.3	0.70	206					C	C		61	2.1	05	
	15.9	87.8	0.37	160	1.4	0.51	218					C	C		72	2.6	06	
	12.6	111.0	0.37	196	1.1	0.41	218					C	C		70	2.0	07	
IEC 71 - 63	10.1	139	0.37	231	0.9	0.35	218					C			66	3.2	08	
	8.4	166	0.25	170	1.3	0.32	218					C			60	2.7	09	
	6.7	208	0.25	195	1.0	0.25	194					C			55	2.1	10	
	4.5	310	0.18	194	1.0	0.18	194					C			51	1.5	11	
	3.8	370	0.18	213	0.9	0.16	194					C			47	1.3	12	
	3.2	434	0.18*	143	<0.8	0.11	143					C			42	1.1	13	

■ Motor Flanges Available Flange Motore Disponibili
B Supplied with Reduction Bushing Fornito con Bussola di Riduzione
B Available on Request without reduction bushing Disponibile a Richiesta senza Bussola di Riduzione
C Motor Flange Holes Position Posizione Fori Flangia Motore

* Power higher than the maximum one which can be supported by the gearbox. Select according to the torque M_{2R}
 Potenza superiore a quella massima sopportabile dal riduttore. Selezionare in base al momento torcente M_{2R}

EN Unit P6A is supplied with synthetic oil, providing "long life" lubrication. For mounting position V5-V6 please contact us. See table 1 for lubrication and recommended quantity. In table 2 please see possible radial loads and axial loads on the gearbox.

I Il riduttore tipo P6A viene fornito lubrificato a vita con olio sintetico. Per posizioni V5-V6 contattare il ns. servizio tecnico. Vedi tab.1 per oli e quantità consigliati. In tab.2 sono presenti i carichi radiali e assiali applicabili al riduttore.

D Für die Lebensdauerschmierung ist das Getriebe der Größe P6A mit synthetischem Öl befüllt. Bei Einbaulage V5 oder V6 bitten wir um Rücksprache. In Tabelle 1 ist die Schmiermenge und das empfohlene Schmiermittel angegeben. In Tabelle 2 sind die zulässigen Radial- und Axialbelastungen des Getriebes aufgeführt.

F Le réducteur de type P6A est fourni lubrifié à vie avec de l'huile synthétique. Concernant les positions V5,V6, contactez notre service d'assistance technique. Voir tableau 1 concernant les huiles et les quantités conseillées. Les charges radiales et axiales applicables au réducteur sont précisées dans le tableau 2.

E El reductor tamaño P6A se suministra, lubricado de por vida con aceite sintético. Para las posiciones V5 y V6 contactar con nuestro servicio técnico. Ver tabla 1, para cantidades y aceites recomendados. En la tabla 2, se encuentran las cargas radiales y axiales admitidas por el reductor.

LUBRICATION P6A Oil

For B3-V5-V6 separate lubrication for A (0.40 l) B (0.08 l), for B6-B7-B8 common lubrication 0.38 l (A + B).

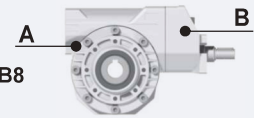

AGIP Telium VSF 320

SHELL Omala S4 WE 320

For all details on lubrication and plugs check our website **tab. 1**
 Per maggiori dettagli su lubrificazione e tappi olio vedi il nostro sito web

RADIAL AND AXIAL LOADS

Output shaft

Albero di uscita

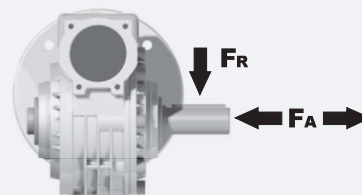

n ₂ [min ⁻¹]	FA [N]	FR [N]
75	500	2500
50	600	3000
25	700	3800
15-6	800	4000

Input shaft

albero in entrata

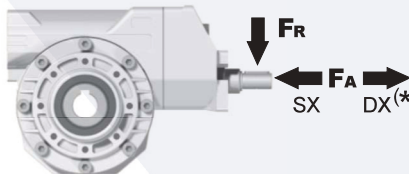

n ₁ [min ⁻¹]	FA [N]	FR [N]
1400	61	305

*Strong axial loads in the DX direction are not allowed.
 Non sono consentiti forti carichi assiali con direzione DX

tab. 2

PP6AFB... Basic wormbox
Riduttore base

M.flange	Kit code	øF	A
29.9-111			
71B5	K063.4.042	160	176.5
80/90B5	K063.4.043	200	178.5
71B14	K063.4.047	105	176.5
80B14	K063.4.046	120	178.5
90B14	K063.4.041	140	178.5
139-434			
63B5	K050.4.041	138	162.5
71B5	K050.4.042	160	160
63B14	K050.4.047	90	162.5
71B14	K050.4.045	105	160

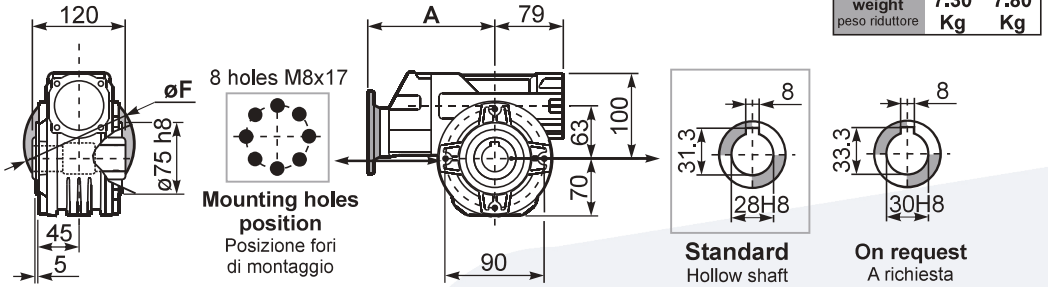

PP6APA... Feet
Piedini

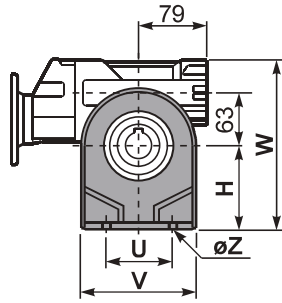
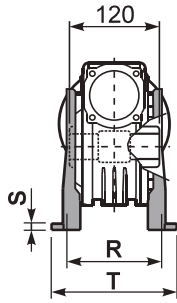

PP6APB... Feet
Piedini

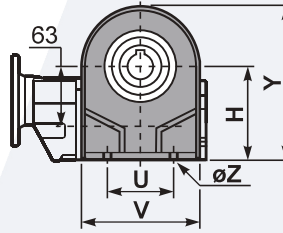

PP6APV... Feet
Piedini

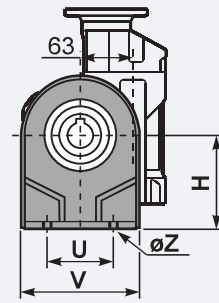

	H	R	S	T	U	V	Y	W	øZ	kit code
type B	115	115	12	142	120	156	185	215	ø11	K070.9.022
type S	-	-	-	-	-	-	-	-	-	-

PP6AFC... Output flange
Flangia uscita

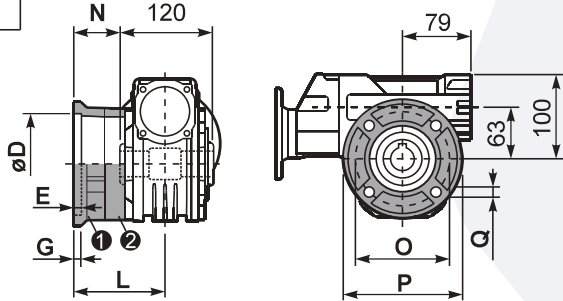

type B	øD	E	G	L	N	O	P	Q	kit code
FC	130 ^{+0.20} / _{+0.15}	7	13	85	25	165	200	13	① K070.9.010 ② -
FL	130 ^{+0.20} / _{+0.15}	7	13	111	51	165	200	13	① K070.9.010 ② K070.0.200
type S	øD	E	G	L	N	O	P	Q	kit code
F1	130 ^{+0.20} / _{+0.15}	7	13	111	51	165	200	13	① KS070.9.014 ② -
F2	115 ^{+0.20} / _{+0.15}	7	13	116	56	150	175	11	① KS063.9.013 ② -
F3	110 ^{+0.035} / ₀	5	13.5	84.5	24.5	130	160	11	① KS070.9.011 ② -

PP6ABR... Reaction arm
Braccio di reazione

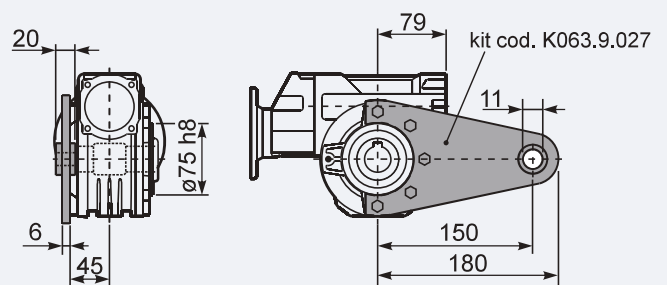

PP6A.....S... Single Shaft
Albero lento semplice

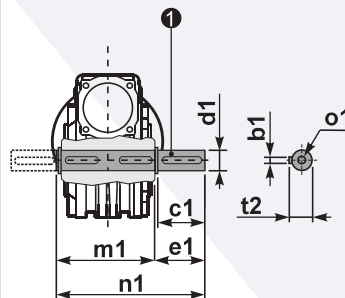

① kit cod. K070.5.028 type B

PP6A.....D... Double Shaft
Albero lento bisp.

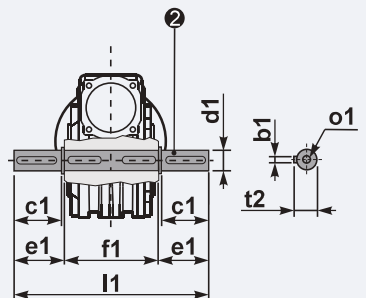

② kit cod. K070.5.029 type B

	b1	c1	d1	e1	f1	l1	m1	n1	t2	o1
type B	8	60	28 ^{-0.005} / _{-0.020}	63.5	120	247	127.5	191	31	M8x20
type S	-	-	-	-	-	-	-	-	-	-

RP6AFB... Input shaft
Albero in entrata

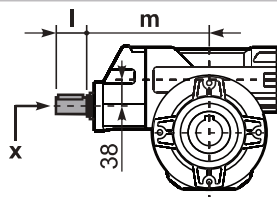
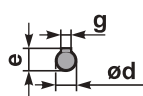

	ød	e	g	l	m	x
29.9-111	19 h6	21.5	6	35	169.4	M6x16
139-434	14 h6	16	5	25	154.2	M5x13