

■ QUICK SELECTION / Selezione veloce										input speed (n <sub>1</sub> ) = 1400 min <sup>-1</sup>			
Output Speed n <sub>2</sub> [min <sup>-1</sup> ]	Ratio i	Motor power P <sub>1M</sub> [kW]	Output torque M <sub>2M</sub> [Nm]	Service factor f.s.	Nominal power P <sub>1R</sub> [kW]	Nominal torque M <sub>2R</sub> [Nm]	Available B5 motor flanges		Available B14 motor flanges		Dynamic efficiency RD	Tooth Module [mm]	Ratios code
							-A	-B	-O	-P			
5.6	<b>252</b>	0.18	142	1.6	<b>0.29</b>	<b>230</b>	B		B-C		46	2.7	01
3.9	<b>360</b>	0.18	181	1.3	<b>0.23</b>	<b>230</b>	B		B-C		41	2.7	02
2.6	<b>540</b>	0.12	164	1.4	<b>0.17</b>	<b>230</b>	B		B-C		37	2.7	03
1.9	<b>720</b>	0.12	200	1.1	<b>0.14</b>	<b>230</b>	B		B-C		34	2.7	04
1.3	<b>1080</b>	0.12	265	0.9	<b>0.10</b>	<b>230</b>	B		B-C		30	2.7	05
1.0	<b>1440</b>	0.12*	230	<0.8	<b>0.09</b>	<b>230</b>	B		B-C		27	2.7	06
0.5	<b>2745</b>	0.12*	230	<0.8	<b>0.05</b>	<b>230</b>	B		B-C		23	2.1	07

■ Motor Flanges Available Flange Motore Disponibili  
B Supplied with Reduction Bushing Fornito con Bussola di Riduzione  
B Available on Request without reduction bushing Disponibile a Richiesta senza Bussola di Riduzione  
C Motor Flange Holes Position Posizione Fori Flangia Motore

\* Power higher than the maximum one which can be supported by the gearbox. Select according to the torque M<sub>2R</sub>  
Potenza superiore a quella massima sopportabile dal riduttore. Selezionare in base al momento torcente M<sub>2R</sub>

**EN** Unit 633 is supplied with synthetic oil, providing "long life" lubrication. For mounting position V5-V6 please contact us. See table 1 for lubrication and recommended quantity. In table 2 please see possible radial loads and axial loads on the gearbox.

**I** Il riduttore tipo 633 viene fornito lubrificato a vita con olio sintetico. Per posizioni V5-V6 contattare il ns. servizio tecnico. Vedi tab.1 per oli e quantità consigliati. In tab.2 sono presenti i carichi radiali e assiali applicabili al riduttore.

**D** Für die Lebensdauerschmierung ist das Getriebe der Größe 633 mit synthetischem Öl befüllt. Bei Einbaulage V5 oder V6 bitten wir um Rücksprache. In Tabelle 1 ist die Schmiermenge und das empfohlene Schmiermittel angegeben. In Tabelle 2 sind die zulässigen Radial- und Axialbelastungen des Getriebes aufgeführt.

**F** Le réducteur de type 633 est fourni lubrifié à vie avec de l'huile synthétique. Concernant les positions V5.V6, contactez notre service d'assistance technique. Voir tableau 1 concernant les huiles et les quantités conseillées. Les charges radiales et axiales applicables au réducteur sont précisées dans le tableau 2.

**E** El reductor tamaño 633 se suministra, lubricado de por vida con aceite sintético. Para las posiciones V5 y V6 contactar con nuestro servicio técnico. Ver tabla 1, para cantidades y aceites recomendados. En la tabla 2, se encuentran las cargas radiales y axiales admitidas por el reductor.

■ LUBRICATION 633 Oil 0.40 Lt.  
Quantity 0.40/0.03 Lt.

AGIP Telium VSF 320	SHELL Omala S4 WE 320
---------------------	-----------------------

For all details on lubrication and plugs check our website **tab. 1**  
Per maggiori dettagli su lubrificazione e tappi olio vedi il nostro sito web

**■ RADIAL AND AXIAL LOADS**

**Output shaft**  
Albero di uscita

n <sub>2</sub> [min <sup>-1</sup> ]	FA [N]	FR [N]
25	700	3800
15	800	4000

**Input shaft**  
albero in entrata

n <sub>1</sub> [min <sup>-1</sup> ]	FA [N]	FR [N]
1400	20	100

**\*Strong axial loads in the DX direction are not allowed.**  
Non sono consentiti forti carichi assiali con direzione DX

tab. 2

**P633FB...** Basic wormbox  
Riduttore base

M. flanges	Kit code	øF	A
56B5	K030.4.041	120	61.5
63B5	K030.4.042	140	62.5
56B14	K030.4.046	80	61.5
63B14	K030.4.045	90	62.5

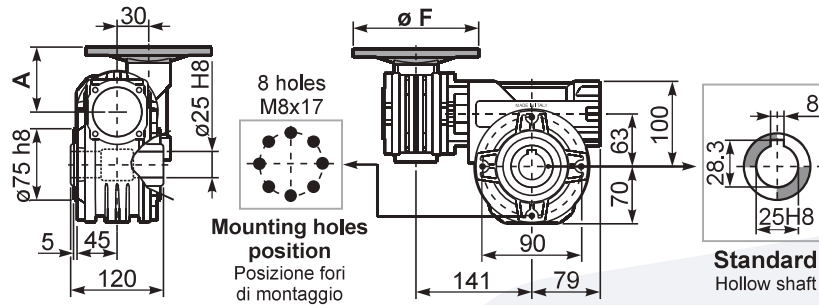

Gearbox weight peso riduttore **7.50 kg**

**P633PA...** Feet  
Piedini

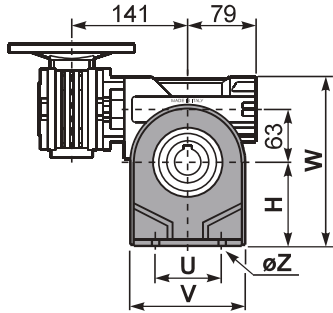
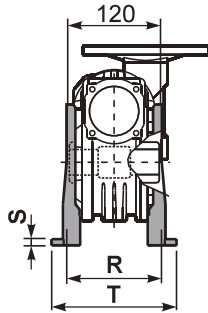

**P633PB...** Feet  
Piedini

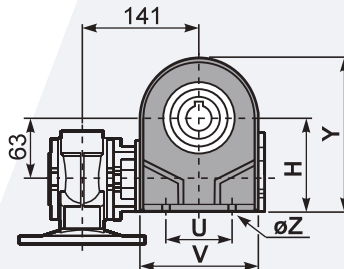

**P633PV...** Feet  
Piedini

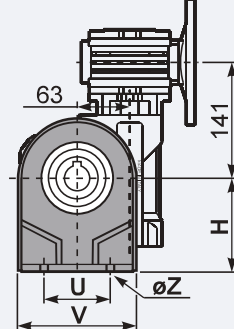

	H	R	S	T	U	V	Y	W	øZ	kit code
type B	100	111	4	144	95	133	170	200	ø10.5	K063.9.022
type S	-	-	-	-	-	-	-	-	-	-

**P633FC...** Output flange  
Flangia uscita

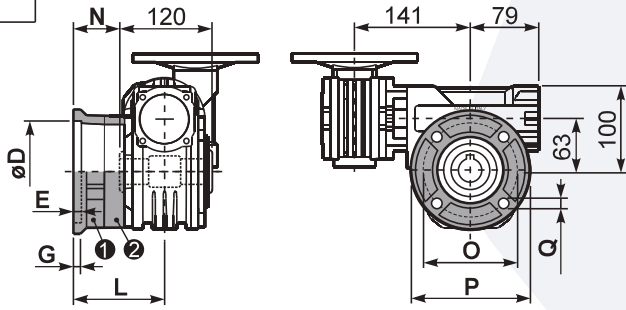

**P633BR...** Reaction arm  
Braccio di reazione

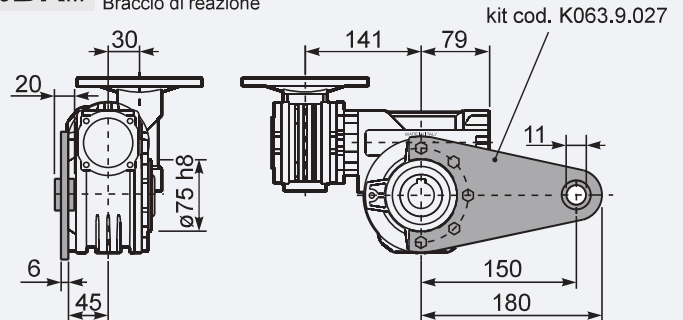

type B	øD	E	G	L	N	O	P	Q	kit code
FC	115 <sup>+0.20</sup> / <sub>+0.15</sub>	7	13	86	26	150	175	11	① K063.9.010 ② -
FL	115 <sup>+0.20</sup> / <sub>+0.15</sub>	7	13	116	56	150	175	11	① K063.9.010 ② K063.0.200

  

type S	øD	E	G	L	N	O	P	Q	kit code
F1	130 <sup>+0.20</sup> / <sub>+0.15</sub>	7	13	102	42	165	200	13	① KS070.9.013 ② -
F2	115 <sup>+0.20</sup> / <sub>+0.15</sub>	7	13	116	56	150	175	11	① KS063.9.013 ② -
F3	110 <sup>+0.035</sup> / <sub>0</sub>	5	11	82	22	130	160	10	① KS063.9.011 ② -

**P633.....S...** Single Shaft  
Albero lento semplice

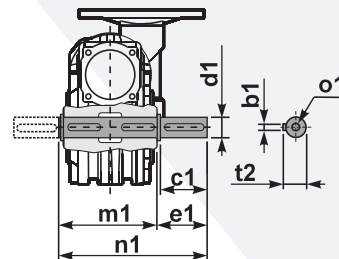

**P633.....D...** Double Shaft  
Albero lento bisp.

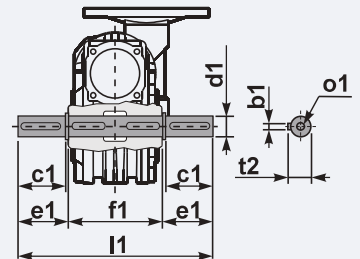

① kit cod. K063.5.028 type B

② kit cod. K063.5.029 type B

**R633FB...** Input shaft  
Albero in entrata

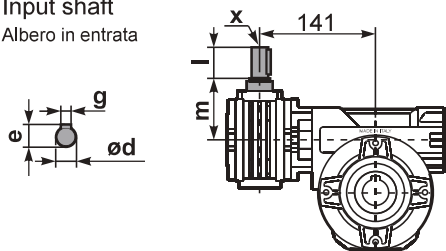

	ød	e	g	l	m	x	kit code
type B	9 h6	10.2	3	20	58	-	① K030.5.006 PAM63 ② -
type S	-	-	-	-	-	-	① - ② -

	b1	c1	d1	e1	f1	l1	m1	n1	t2	o1
type B	8	60	25 <sup>-0.005</sup> / <sub>-0.020</sub>	63.2	120	246.4	126.8	190	28	M8x20
type S	-	-	-	-	-	-	-	-	-	-