

QUICK SELECTION / Selezione veloce

input speed (n_1) = 1400 min⁻¹

Output Speed n_2 [min ⁻¹]	Ratio i	Motor power P_{1M} [kW]	Output torque M_{2M} [Nm]	Service factor f.s.	Nominal power P_{1R} [kW]	Nominal torque M_{2R} [Nm]	Available B5 motor flanges		Available B14 motor flanges		Dynamic efficiency RD	Tooth Module [mm]	Ratios code
							-A	-B	-O	-P			
							56	63	56	63			
10.0	140	0.12	57	1.2	0.14	69	B		B-C		50	2.2	01
7.0	200	0.12	79	0.9	0.11	69	B		B-C		48	2.2	02
5.0	280	0.12*	69	<0.8	0.08	69	B		B-C		45	2.4	03
3.3	420	0.12*	69	<0.8	0.07	69	B		B-C		36	1.6	04
2.5	560	0.12*	69	<0.8	0.05	69	B		B-C		33	2.5	05
1.9	740	0.12*	69	<0.8	0.05	69	B		B-C		30	1.8	06
1.5	920	0.12*	69	<0.8	0.04	69	B		B-C		27	1.5	07
1.3	1120	0.12*	69	<0.8	0.03	69	B		B-C		26	2.5	08
0.9	1480	0.12*	69	<0.8	0.03	69	B		B-C		24	1.8	09
0.8	1840	0.12*	69	<0.8	0.02	69	B		B-C		22	1.5	10
0.6	2400	0.12*	69	<0.8	0.02	69	B		B-C		21	1.2	11

A) Motor Flanges Available
Flange Motore Disponibili

B) Supplied with Reduction Bushing
Fornito con Bussola di Riduzione

B) Available on Request without reduction bushing
Disponibile a Richiesta senza Bussola di Riduzione

C) Motor Flange Holes Position
Posizione Fori Flangia Motore

* Power higher than the maximum one which can be supported by the gearbox. Select according to the torque M_{2R}
Potenza superiore a quella massima sopportabile dal riduttore. Selezionare in base al momento torcente M_{2R}

EN Unit 453 is supplied with synthetic oil, providing "long life" lubrication. For mounting position V5-V6 please contact us. See table 1 for lubrication and recommended quantity. In table 2 please see possible radial loads and axial loads on the gearbox.

I Il riduttore tipo 453 viene fornito lubrificato a vita con olio sintetico. Per posizioni V5-V6 contattare il ns. servizio tecnico. Vedi tab.1 per oli e quantità consigliati. In tab.2 sono presenti i carichi radiali e assiali applicabili al riduttore.

D Für die Lebensdauerschmierung ist das Getriebe der Größe 453 mit synthetischem Öl befüllt. Bei Einbaulage V5 oder V6 bitten wir um Rücksprache. In Tabelle 1 ist die Schmiermenge und das empfohlene Schmiermittel angegeben. In Tabelle 2 sind die zulässigen Radial- und Axialbelastungen des Getriebes aufgeführt.

F Le réducteur de type 453 est fourni lubrifié à vie avec de l'huile synthétique. Concernant les positions V5,V6, contactez notre service d'assistance technique. Voir tableau 1 concernant les huiles et les quantités conseillées. Les charges radiales et axiales applicables au réducteur sont précisées dans le tableau 2.

E El reductor tamaño 453 se suministra, lubricado de por vida con aceite sintético. Para las posiciones V5 y V6 contactar con nuestro servicio técnico. Ver tabla 1, para cantidades y aceites recomendados. En la tabla 2, se encuentran las cargas radiales y axiales admitidas por el reductor.

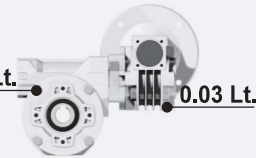
LUBRICATION 453 Oil 0.09 Lt.  0.03 Lt.

Quantity 0.09/0.03 Lt.

AGIP Telium VSF 320	SHELL Omala S4 WE 320
---------------------	-----------------------

For all details on lubrication and plugs check our website **tab. 1**
Per maggiori dettagli su lubrificazione e tappi olio vedi il nostro sito web

RADIAL AND AXIAL LOADS

Output shaft
Albero di uscita

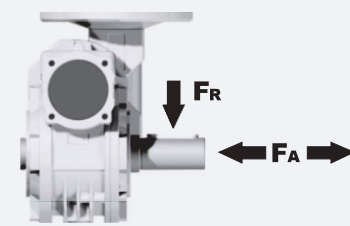

n_2 [min ⁻¹]	FA [N]	FR [N]
25	300	1800
15	400	2000

Input shaft
albero in entrata

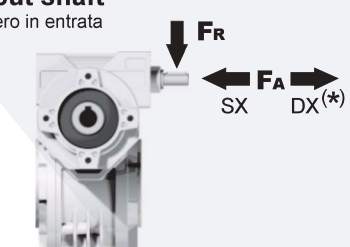

n_1 [min ⁻¹]	FA [N]	FR [N]
1400	20	100

*Strong axial loads in the DX direction are not allowed.
Non sono consentiti forti carichi assiali con direzione DX

tab. 2

P453FB... Basic wormbox
Riduttore base

M. flanges	Kit code	øF	A
56B5	K030.4.041	120	61.5
63B5	K030.4.042	140	62.5
56B14	K030.4.046	80	61.5
63B14	K030.4.045	90	62.5

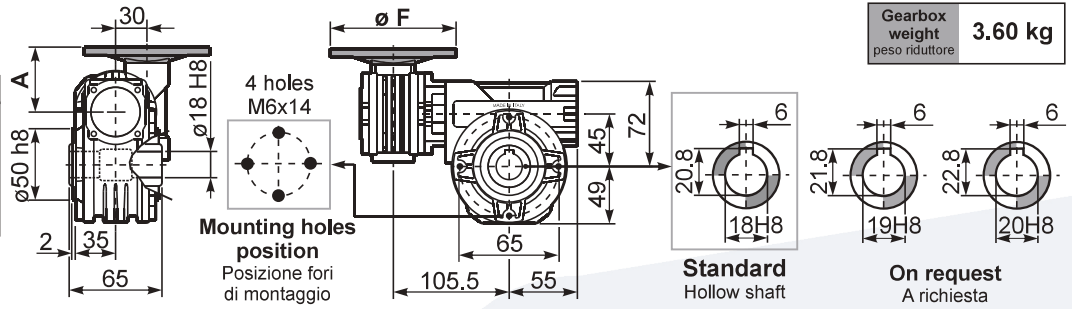

P453PA... Feet
Piedini

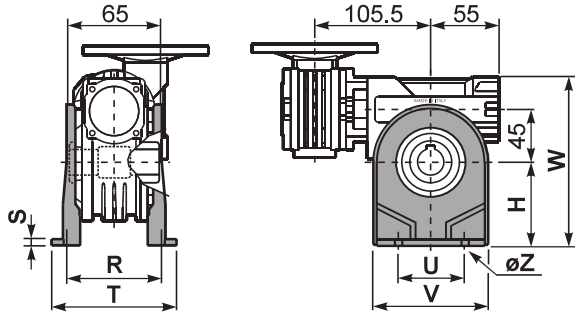

P453PB... Feet
Piedini

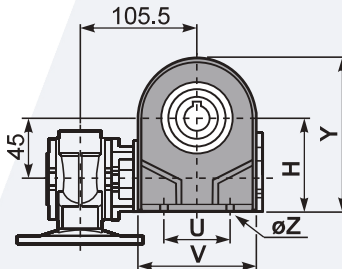

P453PV... Feet
Piedini

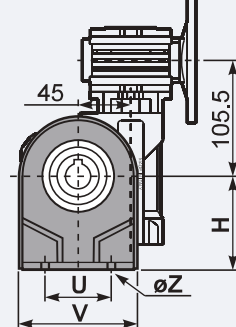

	H	R	S	T	U	V	Y	W	øZ	kit code
type B	72	81	3	100	52	98	121	144	ø10.5	K045.9.022
type S	71	84	8	100	70	90	120	143	ø8	KS045.9.023

P453FC... Output flange
Flangia uscita

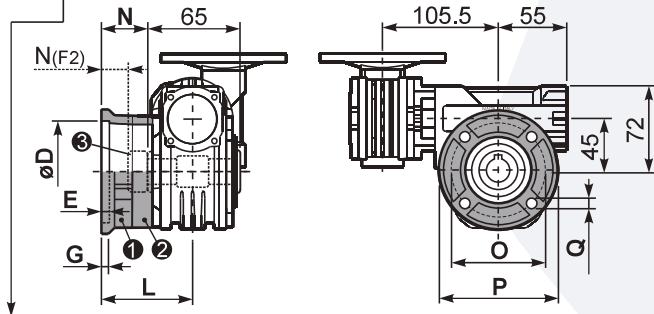

type B	øD	E	G	L	N	O	P	Q	kit code
FC	60 ^{+0.15} / _{-0.05}	9	9	60.5	28	87	110	8.5	① K045.9.010 ② -
FL	60 ^{+0.15} / _{-0.05}	9	9	90.5	58	87	110	8.5	① K045.9.010 ② K045.0.200

type S	øD	E	G	L	N	O	P	Q	kit code
F1	95 ^{+0.20} / _{-0.15}	4	11	73.5	41	115	140	9	① KS045.9.013 ② -
F2	60 ^{+0.15} / _{-0.05}	9	9	60.5	19	87	110	8.5	① KS045.9.010 ② S045.0.204
F3	80 ^{+0.030} / ₀	3	8	51.5	19	100	120	9	① KS045.9.014 ② -

P453BR... Reaction arm
Braccio di reazione

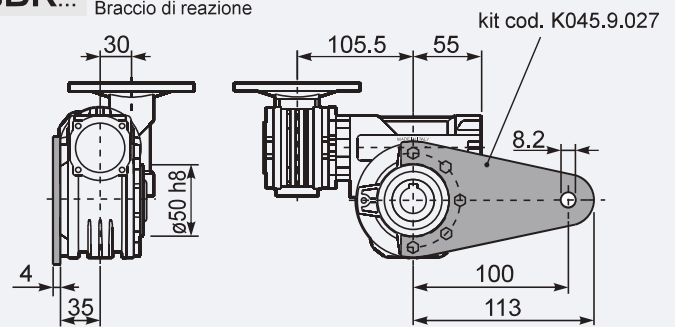

P453.....S... Single Shaft
Albero lento semplice

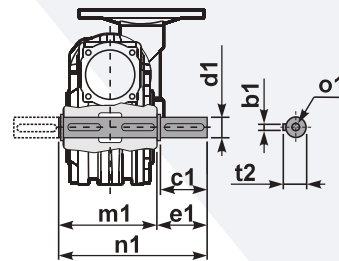

P453.....D... Double Shaft
Albero lento bisp.

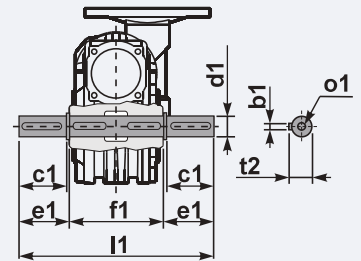

- ① kit cod. K045.5.028 type B
kit cod. KS045.5.030 type S
- ② kit cod. K045.5.029 type B
kit cod. KS045.5.031 type S

R453FB... Input shaft
Albero in entrata

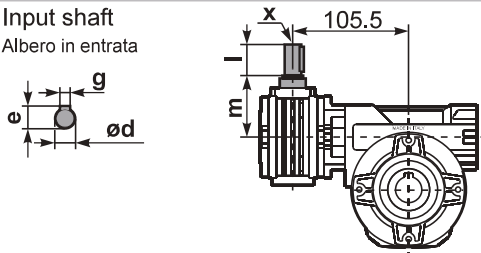

	ød	e	g	l	m	x	kit code
type B	9 h6	10.2	3	20	58	-	① K030.5.006 PAM63 ② -
type S	-	-	-	-	-	-	① - ② -

	b1	c1	d1	e1	f1	l1	m1	n1	t2	o1
type B	6	32	18 ^{-0.005} / _{-0.020}	43	65	151	70	113	20.5	M6x18
type S	6	40	19 ^{-0.005} / _{-0.020}	58.5	65	182	70	128.5	21.5	M8x20