



QUICK SELECTION / Selezione veloce The dynamic efficiency is 0.96 for all ratios **input speed (n₁) = 1400 min⁻¹**

Output Speed n ₂ [min ⁻¹]	Ratio i	Motor power P _{1M} [kW]	Output torque M _{2M} [Nm]	Service factor f.s.	Nominal power P _{1R} [kW]	Nominal torque M _{2R} [Nm]	Available B5 motor flanges					Available B14 motor flanges				Output Shaft 	Ratios code 
							-C	-D	-E	-F	-G	-R	-T	-U	-V		
							71	80	90	100 112	132	80	90	100 112	132		
232	6.03	5.5	211	1.1	6.1	240	B									3011	01
151	9.26	4	238	1.1	4.5	270	B									308	02
123	11.36	4	291	1.2	4.7	350	B									2011	03
91	15.36	4	394	1.0	3.8	385	B									1611	04
80	17.46	4	448	0.9	3.5	400	B									208	05
70	19.97	3	386	1.1	3.1	410	B									1311	06
59	23.60	3	456	0.9	2.7	410	B									168	07
57	24.45	3	472	0.9	2.6	410	B									1111	08
45.6	30.69	2.2	436	0.9	2.0	410	B									138	09
39.6	35.35	1.5	346	1.2	1.8	410	B									811	10
37.3	37.57	1.5	368	1.1	1.7	410	B									118	11
28.8	48.68	1.1	348	1.0	1.1	365	B									611	12
25.8	54.33	1.1	389	1.1	1.2	410	B									88	13
18.7	74.81	0.75	367	1.0	0.73	360	B									68	14

 **Motor Flanges Available** Flange Motore Disponibili
 **B) Supplied with Reduction Bushing** Fornito con Bussola di Riduzione
 **B) Available on Request without reduction bushing** Disponibile a Richiesta senza Bussola di Riduzione
 **C) Motor Flange Holes Position** Posizione Fori Flangia Motore



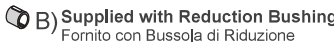
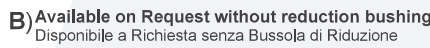
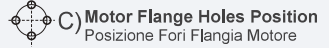



EN Unit X62A is supplied with synthetic oil for lifetime lubrication, no maintenance is necessary. See table 1 for lubrication and recommended quantity. In table 2 please see possible radial loads and axial loads on the gearbox.

I Il riduttore X62A viene fornito completo di olio sintetico per la lubrificazione permanente e non necessita di alcuna manutenzione. Vedi tab.1 per oli e quantità consigliati. In tab.2 sono presenti i carichi radiali e assiali applicabili al riduttore.

D Das Getriebe X62A ist mit synthetischem Öl gefüllt und ist lebensdauergeschmiert. In Tabelle 1 ist die Schmiermenge und das empfohlene Schmiermittel angegeben. In Tabelle 2 sind die zulässigen Radial- und Axialbelastungen des Getriebes aufgeführt.

F Le réducteur X62A est fourni complet avec de l'huile synthétique pour la lubrification permanente et ne nécessite aucun entretien. Voir tableau 1 concernant les huiles et les quantités conseillées. Les charges radiales et axiales applicables au réducteur sont précisées dans le tableau 2.

E El reductor tamaño X62A se suministra, lubricado de por vida con aceite sintético y no requieren mantenimiento alguna. Ver tabla 1, para cantidades y aceites recomendados. En la tabla 2, se encuentran las cargas radiales y axiales admitidas por el reductor.

Standard supplied	For these mounting position specify in the order or add oil Per queste posizioni specificare in fase d'ordine o aggiungere olio						
							
B3	B6	B7	B8	V5	V6	V8	
1.25 LT	1.70 LT	0.95 LT	1.60 LT	2.45 LT	1.50 LT	Ask	
AGIP Telium VSF 320				SHELL Omala S4 WE 320			

For all details on lubrication and plugs check our website **tab. 1**
Per maggiori dettagli su lubrificazione e tappi olio vedi il nostro sito web

RADIAL AND AXIAL LOADS

Output shaft
Albero di uscita

$$F_{eq} = F_R \cdot \frac{69}{X+39}$$

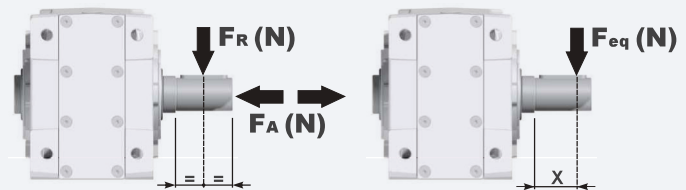

n ₂ [min ⁻¹]	FA	FR	n ₂ [min ⁻¹]	FA	FR	n ₂ [min ⁻¹]	FA	FR
250	600	3000	75	890	4450	15	1660	8300
150	700	3500	50	1140	5700			
100	780	3900	25	1330	6650			

FR On request taper roller bearings to increase radial loads.
A richiesta cuscinetti a rulli conici per aumentare i carichi radiali.

Input shaft
albero in entrata

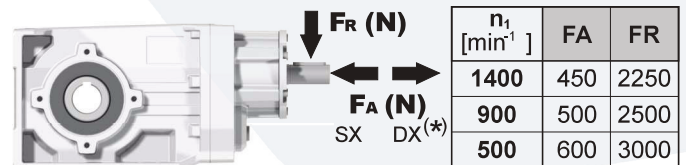

n ₁ [min ⁻¹]	FA	FR
1400	450	2250
900	500	2500
500	600	3000

*Strong axial loads in the DX direction are not allowed.
Non sono consentiti forti carichi assiali con direzione DX

tab. 2

PX62AC... Basic Gearbox
Riduttore base

Gearbox weight
peso riduttore **15.80 kg**

M. flanges	Kit code	øF	A
71B5	K023.4.041	160	253
80/90B5	K023.4.042	200	255
100/112B5	K023.4.043	250	264
132B5	KC50.4.043	300	282
80B14	K085.4.046	120	255
90B14	K085.4.045	140	255
100/112B14	K085.4.047	160	264
132B14	KC50.4.041	200	282

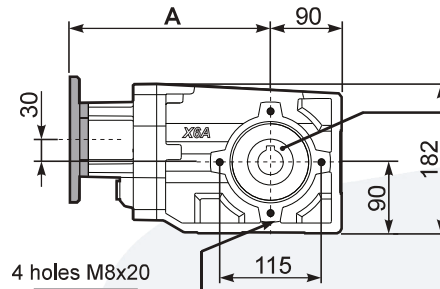
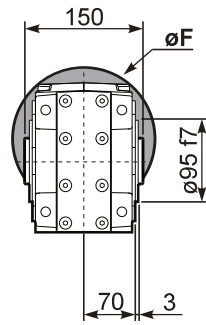

4 holes M8x20
Mounting holes position
Posizione fori di montaggio

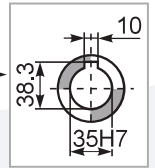

Standard
Hollow shaft

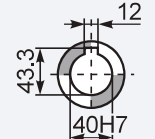

On request
A richiesta

PX62A...FB.. Feet
Piedini

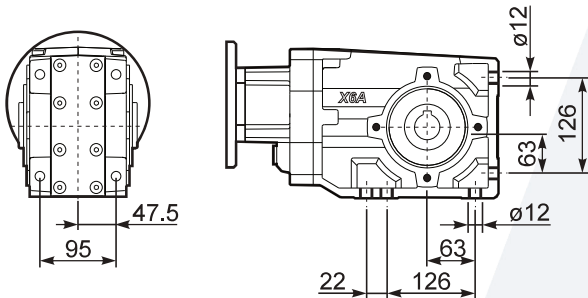

PX62A...-F2.. Output flange
Flangia uscita

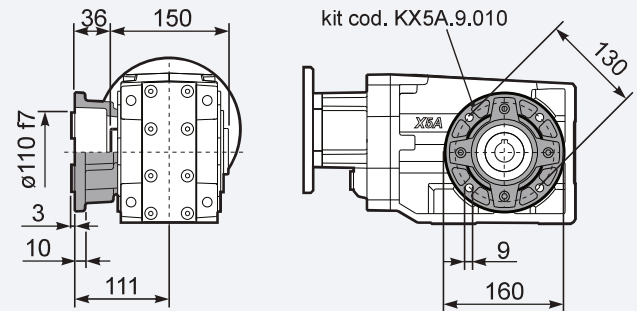

PX62A...-F3.. Output flange
Flangia uscita

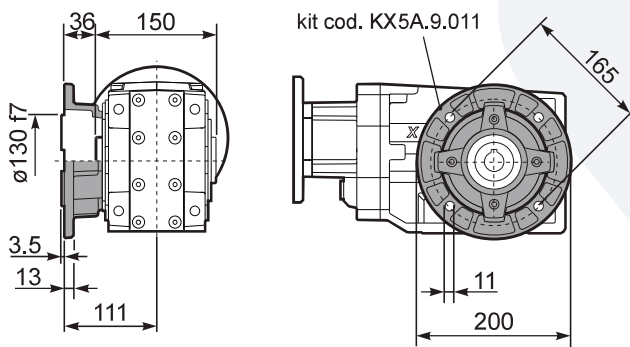

PX62A...-F4.. Output flange
Flangia uscita

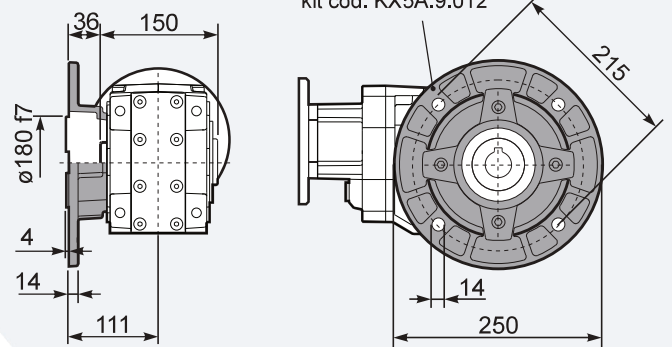

RX62A... Input shaft
Albero in entrata

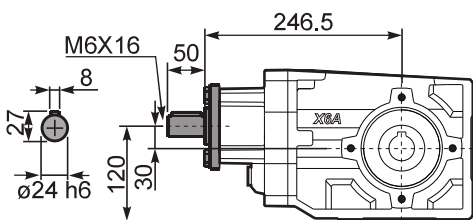

PX62A...BR.. Reaction Arm
Braccio di reazione

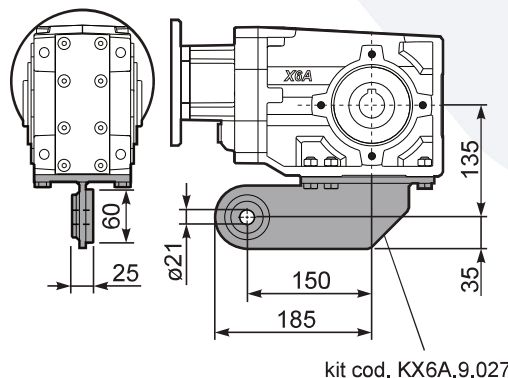

PX62AA.. Single output shaft
Albero semplice in uscita

