



QUICK SELECTION / Selezione veloce The dynamic efficiency is **0.94** for all ratios **input speed (n₁) = 1400 min⁻¹**

Output Speed n ₂ [min ⁻¹]	Ratio i	Motor power P _{1M} [kW]	Output torque M _{2M} [Nm]	Service factor f.s.	Nominal power P _{1R} [kW]	Nominal torque M _{2R} [Nm]	Available B5 motor flanges				Available B14 motor flanges			Output Shaft 	Ratios code
							-B	-C	-D	-E	-Q	-R	-T		
							63	71	80	90	71	80	90		
24.7	56.76	0.55	201	1.2	0.69	250	B				C	C		191311	01
21.3	65.79	0.55	233	1.1	0.59	250	B				C	C		171311	02
18.1	77.23	0.55	274	0.9	0.50	250	B				C	C		151311	03
16.0	87.23	0.37	207	1.2	0.45	250	B				C	C		19138	04
15.2	92.18	0.37	219	1.1	0.42	250	B				C	C		131311	05
13.9	100.47	0.37	238	1.0	0.39	250	B				C	C		19811	06
12.0	116.45	0.37	276	0.9	0.33	250	B				C	C		17811	07
11.1	125.82	0.25	201	1.2	0.31	250	B				C	C		101311	08
9.9	141.66	0.25	227	1.1	0.28	250	B				C	C		13138	09
8.6	163.16	0.25	261	1.0	0.24	250	B				C	C		13811	10
7.8	178.96	0.18	219	1.1	0.22	250	B				C	C		1788	11
7.2	193.36	0.18	237	1.1	0.20	250	B				C	C		10138	12
6.5	216.84	0.18	265	0.9	0.18	250	B				C	C		71311	13
5.5	252.36	0.12	200	1.3	0.15	250	B				C	C		9138	14
4.8	290.67	0.12	230	1.1	0.13	250	B				C	C		9811	15
4.2	333.23	0.12	263	0.9	0.12	250	B				C	C		7138	16
3.6	383.82	0.12	303	0.8	0.10	250	B				C	C		7811	17
3.1	446.70	0.12*	353	0.7	0.09	250	B				C	C		988	18
2.4	589.85	0.12*	466	0.5	0.07	250	B				C	C		788	19

Motor Flanges Available Flange Motore Disponibili
  **B) Supplied with Reduction Bushing** Fornito con Bussola di Riduzione
 B) Available on Request without reduction bushing Disponibile a Richiesta senza Bussola di Riduzione
  **C) Motor Flange Holes Position** Posizione Fori Flangia Motore

* Power higher than the maximum one which can be supported by the gearbox. Select according to the torque M_{2R}
Potenza superiore a quella massima sopportabile dal riduttore. Selezionare in base al momento torcente M_{2R}







EN Unit X53A is supplied with synthetic oil for lifetime lubrication, no maintenance is necessary. See table 1 for lubrication and recommended quantity. In table 2 please see possible radial loads and axial loads on the gearbox.

I Il riduttore X53A viene fornito completo di olio sintetico per la lubrificazione permanente e non necessita di alcuna manutenzione. Vedi tab.1 per oli e quantità consigliati. In tab.2 sono presenti i carichi radiali e assiali applicabili al riduttore.

D Das Getriebe X53A ist mit synthetischem Öl gefüllt und ist lebensdauergeschmiert. In Tabelle 1 ist die Schmiermenge und das empfohlene Schmiermittel angegeben. In Tabelle 2 sind die zulässigen Radial- und Axialbelastungen des Getriebes aufgeführt.

F Le réducteur X53A est fourni complet avec de l'huile synthétique pour la lubrification permanente et ne nécessite aucun entretien. Voir tableau 1 concernant les huiles et les quantités conseillées. Les charges radiales et axiales applicables au réducteur sont précisées dans le tableau 2.

E El reductor tamaño X53A se suministra, lubricado de por vida con aceite sintético y no requieren mantenimiento alguna. Ver tabla 1, para cantidades y aceites recomendados. En la tabla 2, se encuentran las cargas radiales y axiales admitidas por el reductor.

Standard supplied	For these mounting position specify in the order or add oil Per queste posizioni specificare in fase d'ordine o aggiungere olio					
						
1.30 LT	1.55 LT	0.85 LT	1.45 LT	2.10 LT	1.25 LT	Ask
AGIP Telium VSF 320			SHELL Omala S4 WE 320			

For all details on lubrication and plugs check our website **tab. 1**
Per maggiori dettagli su lubrificazione e tappi olio vedi il nostro sito web

RADIAL AND AXIAL LOADS

Output shaft
Albero di uscita

$F_{eq} = F_R \cdot \frac{61.5}{X+31}$

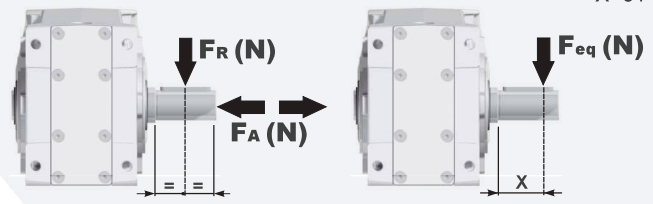

n ₂ [min ⁻¹]	FA	FR	n ₂ [min ⁻¹]	FA	FR	n ₂ [min ⁻¹]	FA	FR
250	600	3000	75	820	4100	15	1660	8300
150	700	3500	50	960	4800			
100	800	4000	25	1350	6750			

F_R On request taper roller bearings to increase radial loads.
A richiesta cuscinetti a rulli conici per aumentare i carichi radiali.

Input shaft
albero in entrata

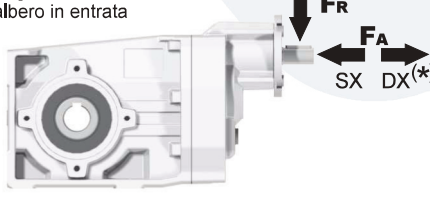

n ₁ [min ⁻¹]	FA [N]	FR [N]
1400	400	2000
900	440	2200
500	440	2200

*Strong axial loads in the DX direction are not allowed.
Non sono consentiti forti carichi assiali con direzione DX

tab. 2

PX53AC... Basic Gearbox
Riduttore base

Gearbox weight
peso riduttore **12.65 kg**

M. flanges	Kit code	øF	A
63B5	K063.4.041	140	246
71B5	K063.4.042	160	244
80/90B5	K063.4.043	200	246
71B14	K063.4.047	105	244
80B14	K063.4.046	120	246
90B14	K063.4.041	140	246

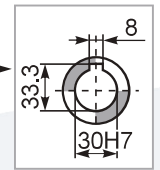
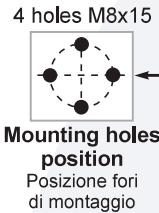
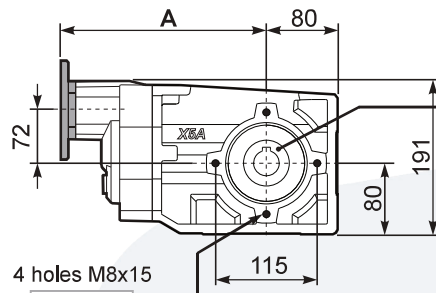
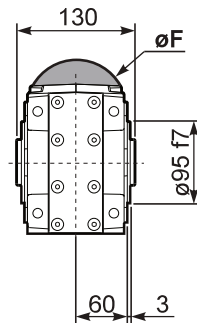

Standard
Hollow shaft

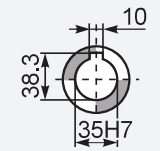

On request
A richiesta

PX53A...FB.. Feet
Piedini

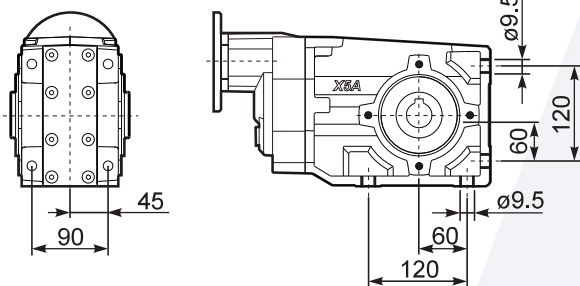

PX53A...-F2.. Output flange
Flangia uscita

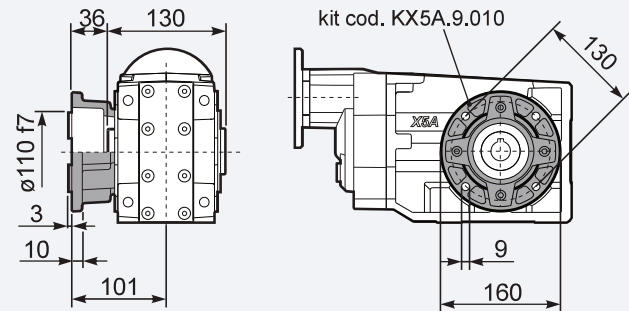

PX53A...-F3.. Output flange
Flangia uscita

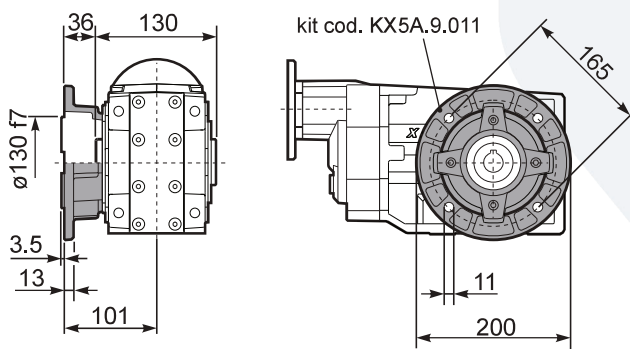

PX53A...-F4.. Output flange
Flangia uscita

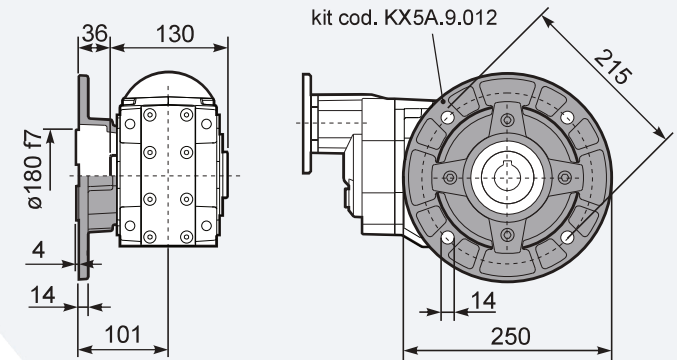

RX53A... Input shaft
Albero in entrata

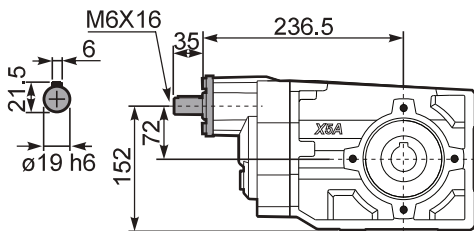

PX53A...BR.. Reaction Arm
Braccio di reazione

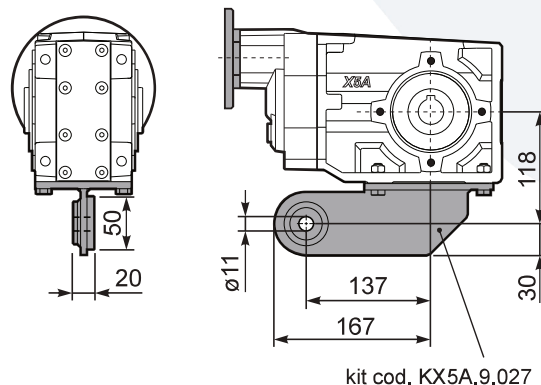

PX53AA.. Single output shaft
Albero semplice in uscita

