

**QUICK SELECTION / Selezione veloce**

input speed ( $n_1$ ) = 1400 min<sup>-1</sup>

Output Speed $n_2$ [min <sup>-1</sup> ]	Ratio $i$	Motor power $P_{1M}$ [kW]	Output torque $M_{2M}$ [Nm]	Service factor f.s.	Nominal power $P_{1R}$ [kW]	Nominal torque $M_{2R}$ [Nm]	Available B5 motor flanges					Available B14 motor flanges				Output Shaft  $\varnothing$	Ratios code 	
							-C	-D	-E	-F	-G	-R	-T	-U	-V			
							71	80	90	100 112	132	80	90	100 112	132			
145	<b>9.69</b>	9	560	1.3	<b>12.2</b>	<b>755</b>	B										302418	01
126	<b>11.09</b>	9	641	1.1	<b>9.6</b>	<b>680</b>	B										302416	02
108	<b>12.90</b>	9	746	1.1	<b>9.6</b>	<b>790</b>	B										302414	03
77	<b>18.26</b>	7.5	849	1.1	<b>8.0</b>	<b>935</b>	B										202418	04
67	<b>20.91</b>	7.5	972	1.0	<b>7.5</b>	<b>1000</b>	B										202416	05
58	<b>24.32</b>	5.5	835	1.2	<b>6.4</b>	<b>1000</b>	B										202414	06
49.5	<b>28.27</b>	5.5	971	1.0	<b>5.5</b>	<b>1000</b>	B										162416	07
42.6	<b>32.88</b>	4	826	1.2	<b>4.7</b>	<b>1000</b>	B										162414	08
38.1	<b>36.76</b>	4	924	1.1	<b>4.2</b>	<b>1000</b>	B										132416	09
32.7	<b>42.76</b>	3	809	1.2	<b>3.6</b>	<b>1000</b>	B										132414	10
31.1	<b>45.00</b>	3	851	1.2	<b>3.5</b>	<b>1000</b>	B										112416	11
26.8	<b>52.33</b>	3	990	1.0	<b>3.0</b>	<b>1000</b>	B										112414	12
24.6	<b>56.82</b>	2.2	791	1.1	<b>2.3</b>	<b>850</b>	B										82418	13
21.5	<b>65.07</b>	2.2	906	1.1	<b>2.3</b>	<b>975</b>	B										82416	14
18.5	<b>75.68</b>	2.2	1054	0.9	<b>2.1</b>	<b>1000</b>	B										82414	15
15.6	<b>89.61</b>	1.1	628	1.1	<b>1.2</b>	<b>710</b>	B										62416	16
13.4	<b>104.22</b>	1.1	731	1.1	<b>1.2</b>	<b>820</b>	B										62414	17

The dynamic efficiency is **0.94** for all ratios

- Motor Flanges Available**  
Flange Motore Disponibili
- B) Supplied with Reduction Bushing**  
Fornito con Bussola di Riduzione
- B) Available on Request without reduction bushing**  
Disponibile a Richiesta senza Bussola di Riduzione
- C) Motor Flange Holes Position**  
Posizione Fori Flangia Motore

**EN** Unit 133C is supplied without lubricant and equipped with a breather, level and drain plugs. User can add mineral oil keeping existing plugs. Should the user wish to fill it with synthetic oil, it is recommended to replace the existing plugs with a closed plug.  
See table 1 for lubrication and recommended quantity.  
In table 2 please see possible radial loads and axial loads on the gearbox.

**I** Il riduttore tipo 133C è fornito privo di lubrificazione con tappi di sfiato, livello e scarico olio. L'utente può immettere olio minerale mantenendo i tappi esistenti. Se immetterà olio sintetico, dovrà sostituire i tappi esistenti con altri tipo chiuso.  
Tab.1 per oli e quantità consigliati.  
Tab.2 carichi radiali e assiali applicabili al riduttore.

**D** Das Getriebe der Baugröße 133C wird ohne Schmiermittel geliefert. Es ist jedoch mit Einfüllschraube, Überdruckventil und Ablassschraube ausgerüstet. Das benötigte mineralische Öl kann über die Einfüllschraube eingefüllt werden. Sollte synthetisches Öl bevorzugt werden, so ist sind das eingebaute Überdruckventil durch eine geschlossenen Schraube zu ersetzen.  
In Tabelle 1 ist die Schmiermenge und das empfohlene Schmiermittel angegeben  
In Tabelle 2 sind die zulässigen Radial - und Axialbelastungen des Getriebes aufgeführt.

**F** Le réducteur de type 133C est fourni sans lubrification et avec un bouchon de remplissage, de niveau et d'évacuation de l'huile. L'utilisateur peut y verser de l'huile minérale en conservant les bouchons existants.  
S'il y versera de l'huile synthétique, il devra substituer les bouchons existants avec d'autres bouchons de type fermé.  
Voir tableau 1 concernant les huiles et les quantités conseillées.  
Voir tableau 2 concernant les charges radiales et axiales applicables au réducteur.

**E** El reductor tamaño 133C se suministra sin lubricante, provisto de tapones de respiración, nivel y descarga de aceite. El usuario puede utilizar aceite mineral, manteniendo los tapones existentes. Si prefiere utilizar aceite sintético deberá sustituir los tapones existentes por tapones ciegos. La prerreducción se suministra con tapones ciegos, lubricado de por vida con aceite sintético.  
Ver tabla 1, para cantidades y aceites recomendados. En la tabla 2, se encuentran las cargas radiales y axiales admitidas por el reductor.

B3	B6	B7	B8	V5	V6	V8
6.00 LT	4.30 LT	4.30 LT	3.30 LT	7.40 LT	3.10 LT	Ask
<b>AGIP Blasias 460</b>						

For all details on lubrication and plugs check our website [www.alpatek.com](#) **tab. 1**  
Per maggiori dettagli su lubrificazione e tappi olio vedi il nostro sito web

### RADIAL AND AXIAL LOADS

**Output shaft**  
Albero di uscita

$n_2$	FA	FR	$n_2$	FA	FR	$n_2$	FA	FR
300	800	4000	140	1120	5600	70	1400	7000
250	900	4500	120	1200	6000	40	1700	8500
200	960	4800	85	1300	6500	15	2400	12000

**On request reinforced bearings to increase loads.**  
A richiesta cuscinetti rinforzati per aumentare i carichi.

$n_1$	FA	FR
1400	450	2250
900	500	2500
500	600	3000

**tab. 2**

**P133CC...** Basic gearbox  
Riduttore base

Gearbox weight  
peso riduttore **53.5 kg**

M. flanges	Kit code	øF	A
71B5	K023.4.041	160	251
80/90B5	K023.4.042	200	253
100/112B5	K023.4.043	250	262
132B5	KC50.4.043	300	280
80B14	K085.4.046	120	253
90B14	K085.4.045	140	253
100/112B14	K085.4.047	160	262
132B14	KC50.4.041	200	280

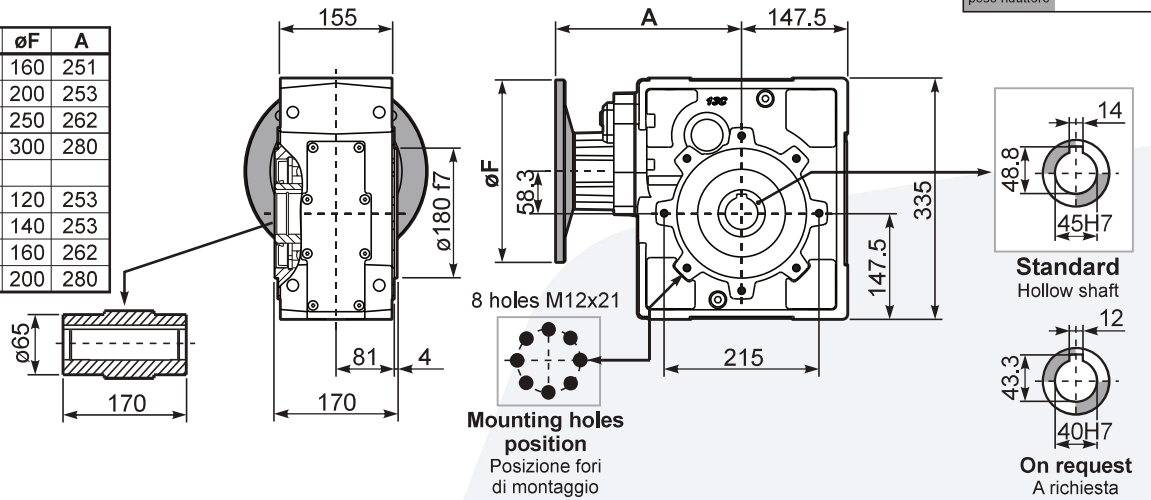

**P133C...FB..** Feet  
Piedini

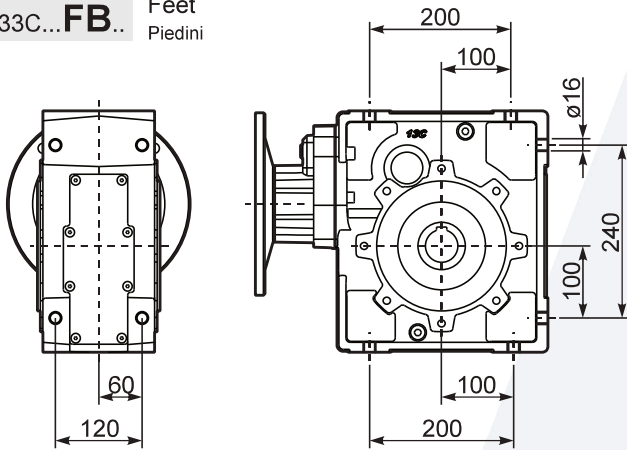

**P133C...-FC..** Output flange  
Flangia uscita

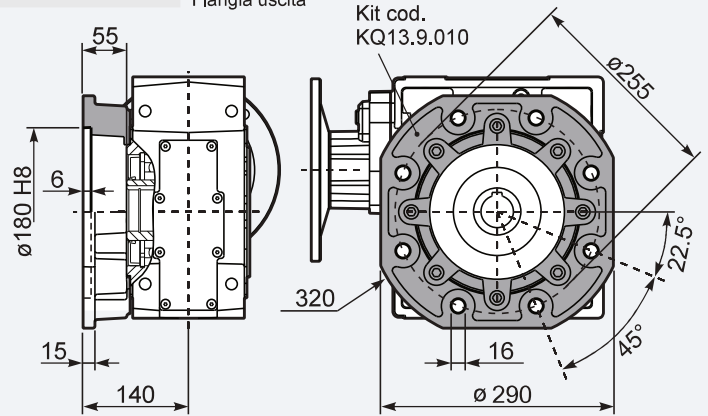

**R133C...** Input Shaft  
Albero in entrata

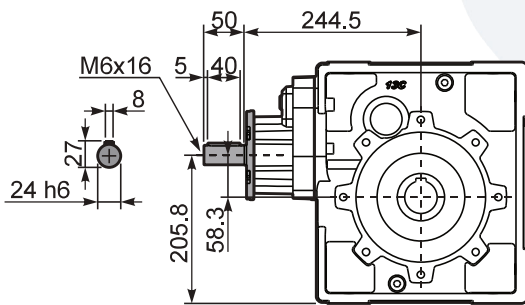

**P133C...BR..** Reaction arm  
Braccio di reazione

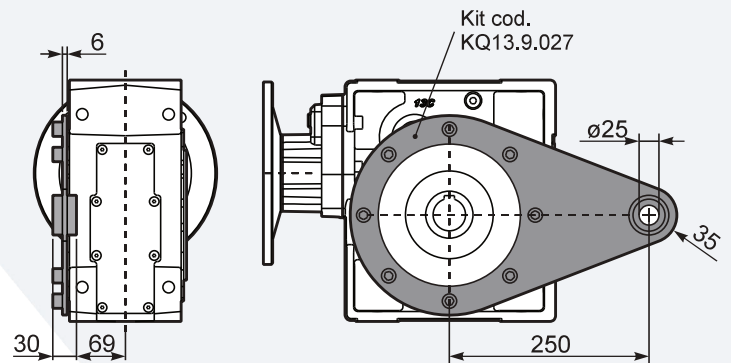

**P133CA..** Single output Shaft  
Albero lento semplice

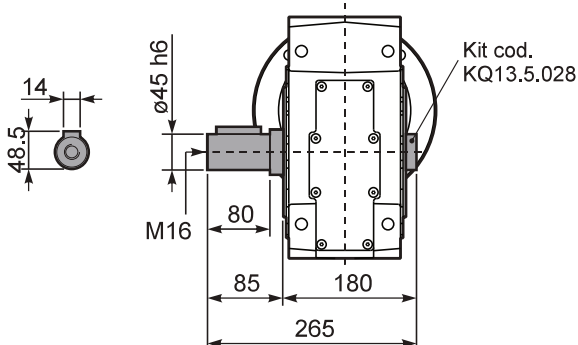

**P133CB..** Double Input Shaft  
Albero lento bisporgente

