

QUICK SELECTION / Selezione veloce

input speed (n_1) = 1400 min⁻¹

Output Speed n_2 [min ⁻¹]	Ratio i	Motor power P_{1M} [kW]	Output torque M_{2M} [Nm]	Service factor f.s.	Nominal power P_{1R} [kW]	Nominal torque M_{2R} [Nm]	Available B5 motor flanges		B14 motor flanges				Output Shaft	Ratios code	
							-H	-I	-	-	-	-			-
528	2.65	22	374	1.7	36.7	650									
409	3.42	22	483	1.6	32.8	750									
304	4.60	22	649	1.5	30.9	950									
256	5.46	22	771	1.3	27.4	1000									
211	6.64	22	937	1.3	26.5	1175									

The dynamic efficiency is **0.98** for all ratios

A) Motor Flanges Available
Flange Motore Disponibili

B) Supplied with Reduction Bushing
Fornito con Bussola di Riduzione

B) Available on Request without reduction bushing
Disponibile a Richiesta senza Bussola di Riduzione

C) Motor Flange Holes Position
Posizione Fori Flangia Motore

EN Unit **901C** is supplied without lubricant and equipped with a breather, level and drain plugs. User can add mineral oil keeping existing plugs. Should the user wish to fill it with synthetic oil, it is recommended to replace the existing plugs with a closed plug. See table 1 for lubrication and recommended quantity. In table 2 please see possible radial loads and axial loads on the gearbox.

I Il riduttore tipo **901C** è fornito privo di lubrificazione con tappi di sfiato, livello e scarico olio. L'utente può immettere olio minerale mantenendo i tappi esistenti. Se immetterà olio sintetico, dovrà sostituire i tappi esistenti con altri tipo chiuso. Tab.1 per oli e quantità consigliati. Tab.2 carichi radiali e assiali applicabili al riduttore.

D Das Getriebe der Baugröße **901C** wird ohne Schmiermittel geliefert. Es ist jedoch mit Einfüllschraube, Überdruckventil und Ablassschraube ausgerüstet. Das benötigte mineralische Öl kann über die Einfüllschraube eingefüllt werden. Sollte synthetisches Öl bevorzugt werden, so ist sind das eingebaute Überdruckventil durch eine geschlossenen Schraube zu ersetzen. In Tabelle 1 ist die Schmiermenge und das empfohlene Schmiermittel angegeben. In Tabelle 2 sind die zulässigen Radial - und Axialbelastungen des Getriebes aufgeführt.

F Le réducteur de type **901C** est fourni sans lubrification et avec un bouchon de remplissage, de niveau et d'évacuation de l'huile. L'utilisateur peut y verser de l'huile minérale en conservant les bouchons existants. S'il y versera de l'huile synthétique, il devra substituer les bouchons existants avec d'autres bouchons de type fermé. Voir tableau 1 concernant les huiles et les quantités conseillées. Voir tableau 2 concernant les charges radiales et axiales applicables au réducteur.

E El reductor tamaño **901C** se suministra sin lubricante, provisto de tapones de respiración, nivel y descarga de aceite. El usuario puede utilizar aceite mineral, manteniendo los tapones existentes. Si prefiere utilizar aceite sintético deberá sustituir los tapones existentes por tapones ciegos. La prerreducción se suministra con tapones ciegos, lubricado de por vida con aceite sintético. Ver tabla 1, para cantidades y aceites recomendados. En la tabla 2, se encuentran las cargas radiales y axiales admitidas por el reductor.

B3	B6	B7	B8	V5	V6	V8
5.90 LT	3.80 LT	3.80 LT	3.50 LT	6.80 LT	4.50 LT	Ask

AGIP Blasias 460
tab. 1

For all details on lubrication and plugs check our website
Per maggiori dettagli su lubrificazione e tappi olio vedi il nostro sito web

RADIAL AND AXIAL LOADS

Output shaft
Albero di uscita

$F_{eq} = FR \cdot \frac{88.5}{X+38.5}$

n_2	FA	FR	n_2	FA	FR	n_2	FA	FR
300	2070	10350	140	2760	13800	70	3450	17250
250	2300	11500	120	2990	14950	40	3680	18400
200	2530	12650	85	3220	16100	15	4600	23000

On request reinforced bearings to increase loads.
A richiesta cuscinetti rinforzati per aumentare i carichi.

tab. 2

P901C**S8**... With feet
Con piedini

Gearbox weight
peso riduttore With flange **102 kg**
With feet **110.5 kg**

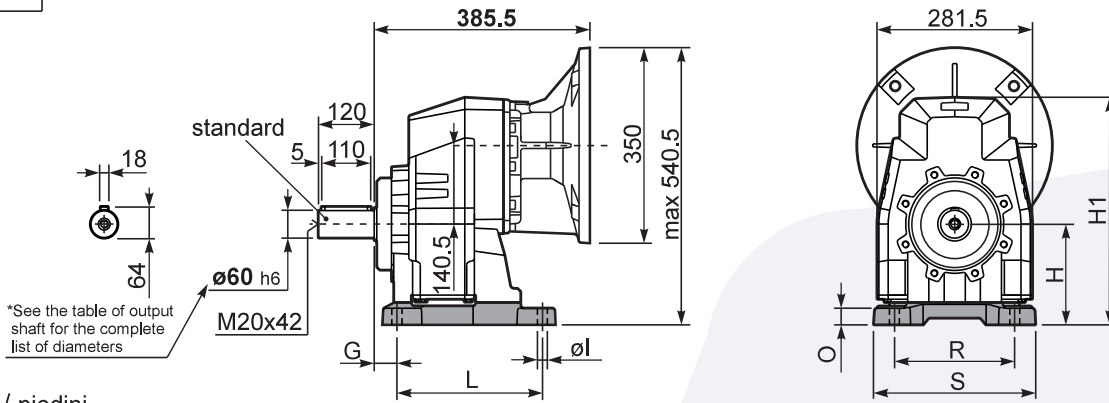

Feet / piedini

Feet Code	Market reference	G	H	R	L	S	H1	O	øI	B5 max. Flange	kit code
B6	612/3	25	195	250	180	300	422	25	18	-	KC90.9.022
B7	702/3	25	210	300	165	350	437	30	22	-	KC90.9.027
S8	87	40	180	215	260	290	407	30	18	-	KC90.9.024
S9	97	40	225	250	310	340	452	45	22	-	KC90.9.026
H7	027/273	40	225	250	245	300	452	55	22	-	KC90.9.023
HS	-	40	175	215	260	290	402	25	18	-	KC90.9.025

P901C-**F**... Output flanges
flange di uscita

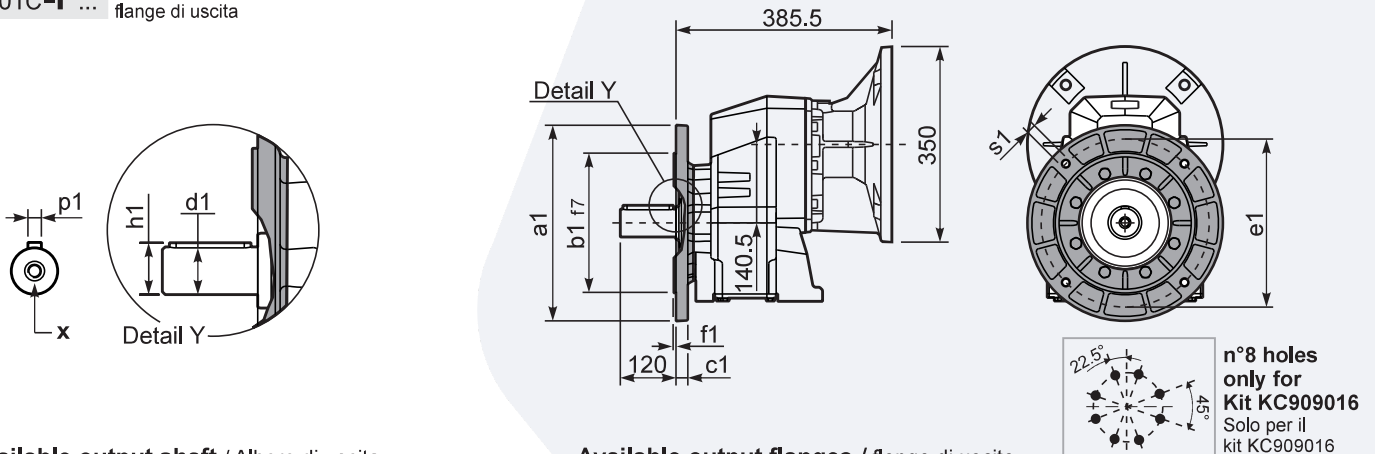

*Available output shaft / Albero di uscita

	Shaft - d1	p1	h1	x
Standard	ø 60x120	18	64	M20x42
On request A richiesta	ø 50x100	14	53.5	M16x36

Available output flanges / flange di uscita

a1 ø	b1	c1	e1	f1	s1	kit code
300	230	21	265	4	14	KC90.9.014
350	250	21	300	5	18	KC90.9.015
450	350	22	400	5	18	KC90.9.016

With flange and feet
only on request.
Ask for compatibility

P901C-**N**... Basic gearbox
Riduttore base

