





■ **QUICK SELECTION / Selezione veloce**

input speed (n_1) = 1400 min⁻¹

| Output Speed n_2 [min ⁻¹] | Ratio i | Motor power P_{1M} [kW] | Output torque M_{2M} [Nm] | Service factor f.s. | Nominal power P_{1R} [kW] | Nominal torque M_{2R} [Nm] | B5 motor flanges | | | | B14 motor flanges | | | | Output Shaft  | Ratios code  |
|---|--------------|---------------------------------|-----------------------------------|------------------------|-----------------------------------|------------------------------------|---------------------|-----|-----|-----|----------------------|---|---|------|---|--|
| | | | | | | | -F | -G | -H | -I | - | - | - | - | | |
| | | | | | | | 100 112 | 132 | 160 | 180 | - | - | - | - | | |
| 317 | 4.42 | 22 | 611 | 1.1 | 24.2 | 700 | B | | | | | | | 3015 | 01 | |
| 264 | 5.30 | 22 | 733 | 1.0 | 20.2 | 700 | B | | | | | | | 3013 | 02 | |
| 219 | 6.38 | 18.5 | 742 | 1.1 | 19.1 | 800 | B | | | | | | | 3011 | 03 | |
| 168 | 8.33 | 15 | 784 | 1.0 | 14.7 | 800 | B | | | | | | | 2015 | 04 | |
| 140 | 9.99 | 15 | 940 | 1.0 | 13.8 | 900 | B | | | | | | | 2013 | 05 | |
| 124 | 11.26 | 15 | 1060 | 1.0 | 14.9 | 1100 | B | | | | | | | 1615 | 06 | |
| 116 | 12.03 | 15 | 1132 | 1.1 | 15.2 | 1200 | B | | | | | | | 2011 | 07 | |
| 104 | 13.50 | 15 | 1271 | 1.1 | 15.8 | 1400 | B | | | | | | | 1613 | 08 | |
| 96 | 14.65 | 15 | 1378 | 1.1 | 15.6 | 1500 | B | | | | | | | 1315 | 09 | |
| 86 | 16.26 | 15 | 1531 | 1.0 | 14.1 | 1500 | B | | | | | | | 1611 | 10 | |
| 80 | 17.56 | 11 | 1214 | 1.2 | 13.0 | 1500 | B | | | | | | | 1313 | 11 | |
| 65 | 21.50 | 11 | 1486 | 1.1 | 11.4 | 1600 | B | | | | | | | 1113 | 12 | |
| 54 | 25.88 | 9 | 1526 | 1.0 | 9.4 | 1600 | B | | | | | | | 1111 | 13 | |
| 45.0 | 31.09 | 7.5 | 1475 | 1.0 | 7.2 | 1460 | B | | | | | | | 813 | 14 | |
| 37.4 | 37.43 | 5.5 | 1312 | 1.2 | 6.5 | 1600 | B | | | | | | | 811 | 15 | |

The dynamic efficiency is **0.96** for all ratios

-  **Motor Flanges Available**
Flange Motore Disponibili
-  **B) Supplied with Reduction Bushing**
Fornito con Bussola di Riduzione
-  **B) Available on Request without reduction bushing**
Disponibile a Richiesta senza Bussola di Riduzione
-  **C) Motor Flange Holes Position**
Posizione Fori Flangia Motore





EN Unit **852C** is supplied without lubricant and equipped with a breather, level and drain plugs. User can add mineral oil keeping existing plugs. Should the user wish to fill it with synthetic oil, it is recommended to replace the existing plugs with a closed plug.
See table 1 for lubrication and recommended quantity. In table 2 please see possible radial loads and axial loads on the gearbox.

I Il riduttore tipo **852C** è fornito privo di lubrificazione con tappi di sfiato, livello e scarico olio. L'utente può immettere olio minerale mantenendo i tappi esistenti. Se immetterà olio sintetico, dovrà sostituire i tappi esistenti con altri tipo chiuso.
Tab.1 per oli e quantità consigliati.
Tab.2 carichi radiali e assiali applicabili al riduttore.

D Das Getriebe der Baugröße **852C** wird ohne Schmiermittel geliefert. Es ist jedoch mit Einfüllschraube, Überdruckventil und Ablassschraube ausgerüstet. Das benötigte mineralische Öl kann über die Einfüllschraube eingefüllt werden. Sollte synthetisches Öl bevorzugt werden, so ist sind das eingebaute Überdruckventil durch eine geschlossenen Schraube zu ersetzen.
In Tabelle 1 ist die Schmiermenge und das empfohlene Schmiermittel angegeben
In Tabelle 2 sind die zulässigen Radial - und Axialbelastungen des Getriebes aufgeführt.

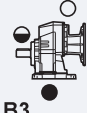
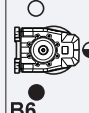
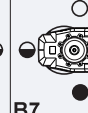
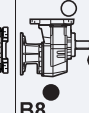
F Le réducteur de type **852C** est fourni sans lubrification et avec un bouchon de remplissage, de niveau et d'évacuation de l'huile. L'utilisateur peut y verser de l'huile minérale en conservant les bouchons existants. S'il y versera de l'huile synthétique, il devra substituer les bouchons existants avec d'autres bouchons de type fermé.
Voir tableau 1 concernant les huiles et les quantités conseillées.
Voir tableau 2 concernant les charges radiales et axiales applicables au réducteur

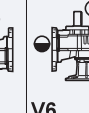
E El reductor tamaño **852C** se suministra sin lubricante, provisto de tapones de respiración, nivel y descarga de aceite. El usuario puede utilizar aceite mineral, manteniendo los tapones existentes. Si prefiere utilizar aceite sintético deberá sustituir los tapones existentes por tapones ciegos. La prerreducción se suministra con tapones ciegos, lubricado de por vida con aceite sintético. Ver tabla 1, para cantidades y aceites recomendados. En la tabla 2, se encuentran las cargas radiales y axiales admitidas por el reductor.

| | | | | | | |
|--|--|---|--|--|--|--|
|  |  |  |  |  |  |  |
| 5.40 LT | 3.60 LT | 3.60 LT | 2.80 LT | 5.90 LT | 4.20 LT | Ask |
| AGIP Blasias 460 | | | | | | |

For all details on lubrication and plugs check our website **tab. 1**
Per maggiori dettagli su lubrificazione e tappi olio vedi il nostro sito web

RADIAL AND AXIAL LOADS

Output shaft
Albero di uscita

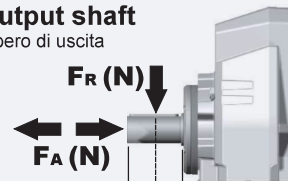

$F_{eq} = FR \cdot \frac{88.5}{X+38.5}$

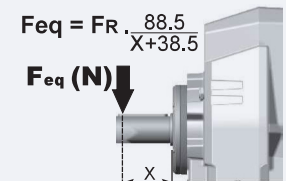

| n_2 | FA | FR | n_2 | FA | FR | n_2 | FA | FR |
|-------|------|-------|-------|------|-------|-------|------|-------|
| 300 | 1800 | 9000 | 140 | 2400 | 12000 | 70 | 3000 | 15000 |
| 250 | 2000 | 10000 | 120 | 2600 | 13000 | 40 | 3200 | 16000 |
| 200 | 2200 | 11000 | 85 | 2800 | 14000 | 15 | 4000 | 20000 |

On request reinforced bearings to increase loads.
A richiesta cuscinetti rinforzati per aumentare i carichi.

Input shaft
Albero in entrata

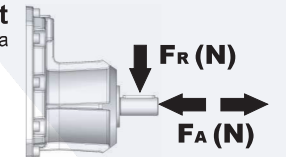

| n_1 | FA | FR |
|-------|-----|------|
| 1400 | 700 | 3500 |
| 900 | 840 | 4200 |
| 500 | 900 | 4500 |

tab. 2

P852C-S8... With foot
Con piedino

Gearbox weight With flange **86.0 kg**
peso riduttore With feet **76.5 kg**

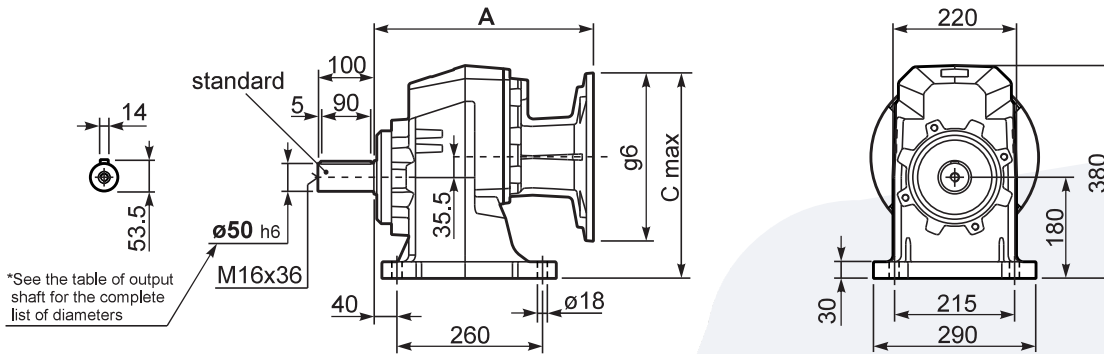

P852C-F... Output flanges
flange di uscita

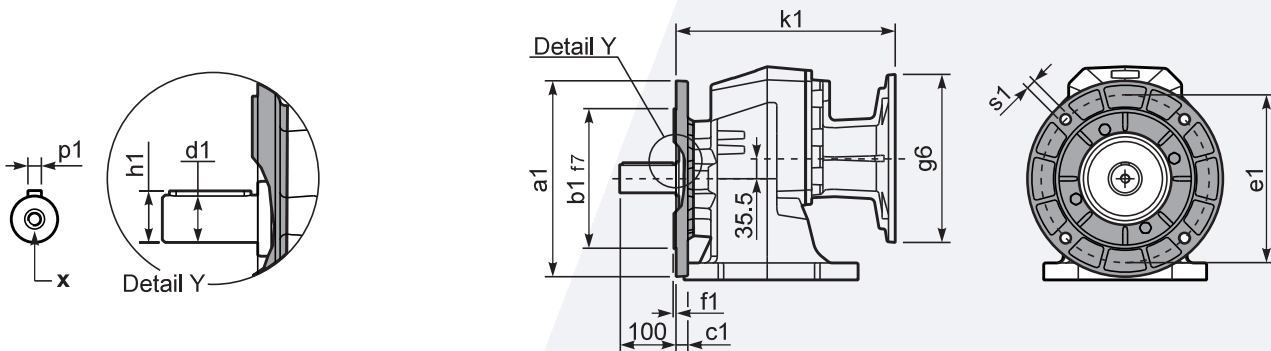

*Available output shaft / Albero di uscita

| | Shaft - d1 | p1 | h1 | x |
|---------------------------|------------|----|------|--------|
| Standard | ∅ 50x100 | 14 | 53.5 | M16x36 |
| On request A richiesta | ∅ 60x120 | 18 | 64 | M20x42 |
| | - | - | - | - |

Available output flanges / flange di uscita

| a1 ∅ | b1 | c1 | e1 | f1 | s1 | kit code |
|------|-----|----|-----|----|----|------------|
| 300 | 230 | 21 | 265 | 4 | 14 | KC90.9.014 |
| 350 | 250 | 21 | 300 | 5 | 18 | KC90.9.015 |
| - | - | - | - | - | - | - |

All flanges are compatible with the foot

P852C-S8... Basic gearbox
Riduttore base

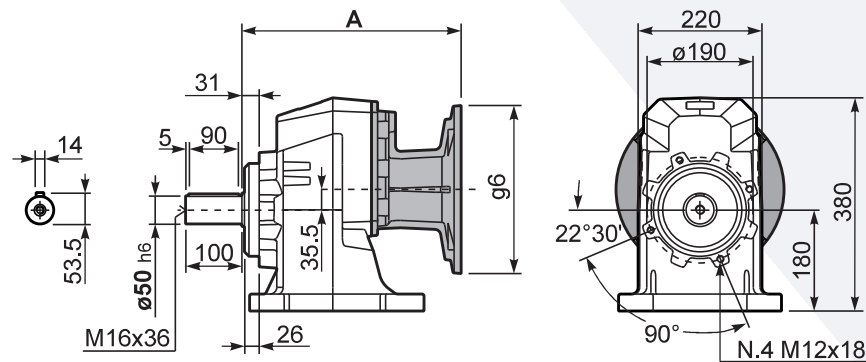

| B5 Motor Flanges | A | C _{max} | g6 | k1 | kit code |
|------------------|-----|------------------|-----|-----|----------|
| 100/112 B5 | 387 | 340.5 | 250 | 387 | - |
| 132 B5 | 391 | 365.5 | 300 | 391 | - |
| 160/180 B5 | 402 | 390.5 | 350 | 402 | - |

R852C-S8... Input Shaft
Albero in entrata

