

QUICK SELECTION / Selezione veloce

input speed (n₁) = 1400 min⁻¹

Output Speed n ₂ [min ⁻¹]	Ratio i	Motor power P _{1M} [kW]	Output torque M _{2M} [Nm]	Service factor f.s.	Nominal power P _{1R} [kW]	Nominal torque M _{2R} [Nm]	Available B5 motor flanges					Available B14 motor flanges				Output Shaft 	Ratios code
							-C	-D	-E	-F	-G	-R	-T	-U	-V		
							71	80	90	100 112	132	80	90	100 112	132		
175	8.02	9	473	1.1	9.9	520	B									3018	01
152	9.18	9	541	1.1	9.8	590	B									3016	02
131	10.68	9	630	1.1	9.7	680	B									3014	03
93	15.11	7.5	717	1.1	7.8	775	B									2018	04
81	17.30	7.5	821	1.1	7.8	885	B									2016	05
70	20.13	7.5	955	0.9	6.8	900	B									2014	06
60	23.39	5.5	820	1.1	5.9	900	B									1616	07
51	27.21	5.5	954	0.9	5.1	900	B									1614	08
46.0	30.42	4	780	1.2	4.5	900	B									1316	09
39.6	35.38	4	907	1.0	3.9	900	B									1314	10
37.6	37.24	3	719	1.2	3.7	895	B									1116	11
32.3	43.31	3	836	1.1	3.2	900	B									1114	12
29.8	47.02	2.2	668	1.1	2.3	705	B									818	13
26.0	53.85	2.2	765	1.1	2.3	810	B									816	14
22.4	62.63	2.2	890	1.0	2.2	900	B									814	15
18.9	74.16	1.1	531	1.1	1.2	585	B									616	16
16.2	86.25	1.1	617	1.1	1.2	680	B									614	17

The dynamic efficiency is 0.96 for all ratios

- Motor Flanges Available** Flange Motore Disponibili
- B) Supplied with Reduction Bushing** Fornito con Bussola di Riduzione
- B) Available on Request without reduction bushing** Disponibile a Richiesta senza Bussola di Riduzione
- C) Motor Flange Holes Position** Posizione Fori Flangia Motore

EN Unit 802C is supplied without lubricant and equipped with a breather, level and drain plugs. User can add mineral oil keeping existing plugs. Should the user wish to fill it with synthetic oil, it is recommended to replace the existing plugs with a closed plug. See table 1 for lubrication and recommended quantity. In table 2 please see possible radial loads and axial loads on the gearbox.

I Il riduttore tipo 802C è fornito privo di lubrificazione con tappi di sfiato, livello e scarico olio. L'utente può immettere olio minerale mantenendo i tappi esistenti. Se immetterà olio sintetico, dovrà sostituire i tappi esistenti con altri tipo chiuso. Tab.1 per oli e quantità consigliati. Tab.2 carichi radiali e assiali applicabili al riduttore.

D Das Getriebe der Baugröße 802C wird ohne Schmiermittel geliefert. Es ist jedoch mit Einfüllschraube, Überdruckventil und Ablassschraube ausgerüstet. Das benötigte mineralische Öl kann über die Einfüllschraube eingefüllt werden. Sollte synthetisches Öl bevorzugt werden, so ist sind das eingebaute Überdruckventil durch eine geschlossenen Schraube zu ersetzen. In Tabelle 1 ist die Schmiermenge und das empfohlene Schmiermittel angegeben. In Tabelle 2 sind die zulässigen Radial - und Axialbelastungen des Getriebes aufgeführt.

F Le réducteur de type 802C est fourni sans lubrification et avec un bouchon de remplissage, de niveau et d'évacuation de l'huile. L'utilisateur peut y verser de l'huile minérale en conservant les bouchons existants. S'il y versera de l'huile synthétique, il devra substituer les bouchons existants avec d'autres bouchons de type fermé. Voir tableau 1 concernant les huiles et les quantités conseillées. Voir tableau 2 concernant les charges radiales et axiales applicables au réducteur

E El reductor tamaño 802C se suministra sin lubricante, provisto de tapones de respiración, nivel y descarga de aceite. El usuario puede utilizar aceite mineral, manteniendo los tapones existentes. Si prefiere utilizar aceite sintético deberá sustituir los tapones existentes por tapones ciegos. La prerreducción se suministra con tapones ciegos, lubricado de por vida con aceite sintético. Ver tabla 1, para cantidades y aceites recomendados. En la tabla 2, se encuentran las cargas radiales y axiales admitidas por el reductor.

B3	B6	B7	B8	V5	V6	V8
3.20 LT	1.90 LT	1.90 LT	1.55 LT	3.20 LT	2.20 LT	Ask

AGIP Blasias 460

For all details on lubrication and plugs check our website **tab. 1**
Per maggiori dettagli su lubrificazione e tappi olio vedi il nostro sito web

RADIAL AND AXIAL LOADS

Output shaft
Albero di uscita

$F_R (N)$
 $F_A (N)$

$F_{eq} = F_R \cdot \frac{80.5}{X+40.5}$

$F_{eq} (N)$

n ₂	FA	FR	n ₂	FA	FR	n ₂	FA	FR
300	1200	6000	140	1600	8000	70	2200	11000
250	1400	7000	120	1800	9000	40	2600	13000
200	1500	7500	85	2000	10000	15	3000	15000

On request reinforced bearings to increase loads.
A richiesta cuscinetti rinforzati per aumentare i carichi.

Input shaft
Albero in entrata

$F_R (N)$
 $F_A (N)$

n ₁	FA	FR
1400	450	2250
900	500	2500
500	600	3000

tab. 2

P802C-S7... With feet
Con piedini

Gearbox weight
peso riduttore With flange **39.5 kg**
With feet **43.5 kg**

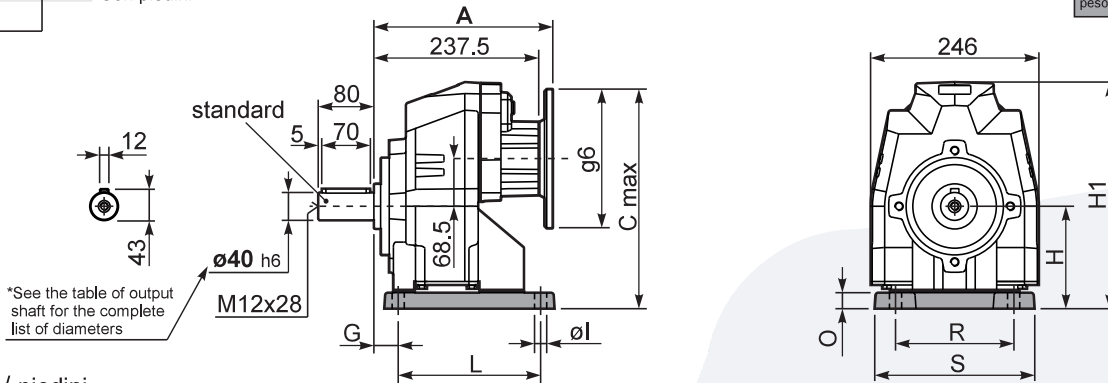

Feet / piedini

Feet Code	Market reference	G	H	R	L	S	H1	O	øI	B5 max. Flange	kit code
B5	512/3	25	155	225	156	270	333.5	30	18	-	KC80.9.022
S7	77	35	140	170	205	230	318.5	18	17.5	-	KC80.9.024
H6	026/263	40	175	215	215	265	353.5	30	16	-	KC80.9.023
-	-	-	-	-	-	-	-	-	-	-	-
-	-	-	-	-	-	-	-	-	-	-	-

P802C-F... Output flanges
flange di uscita

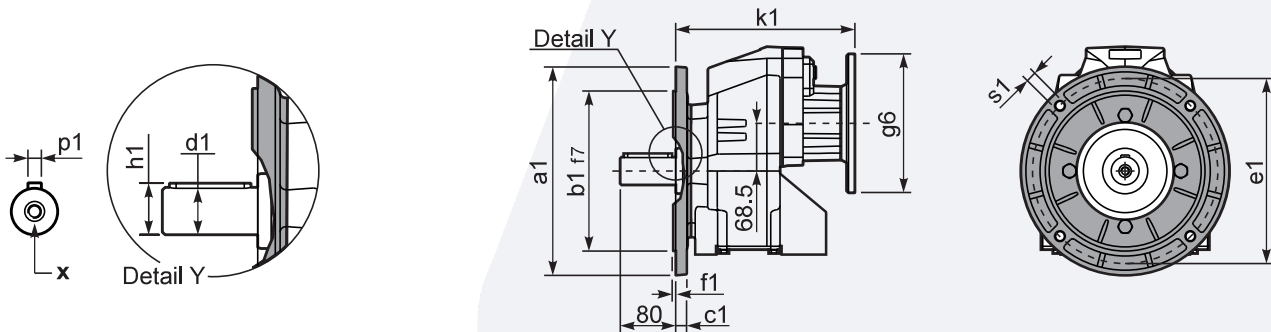

*Available output shaft / Albero di uscita

	Shaft - d1	p1	h1	x
Standard	ø 40x80	12	43	M12x28
On request A richiesta	ø 50x100	14	53.5	M16x36
	-	-	-	-

Available output flanges / flange di uscita

a1 ø	b1	c1	e1	f1	s1	kit code
250	180	13	215	4	14	KC80.9.013
300	230	16	265	4	14	KC80.9.014
-	-	-	-	-	-	-

With flange and feet only on request. Ask for compatibility

P802C-N... Basic gearbox
Riduttore base

R802C-N... Input Shaft
Albero in entrata

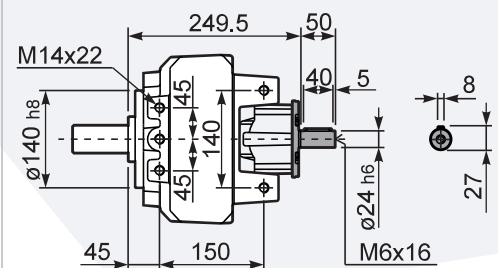
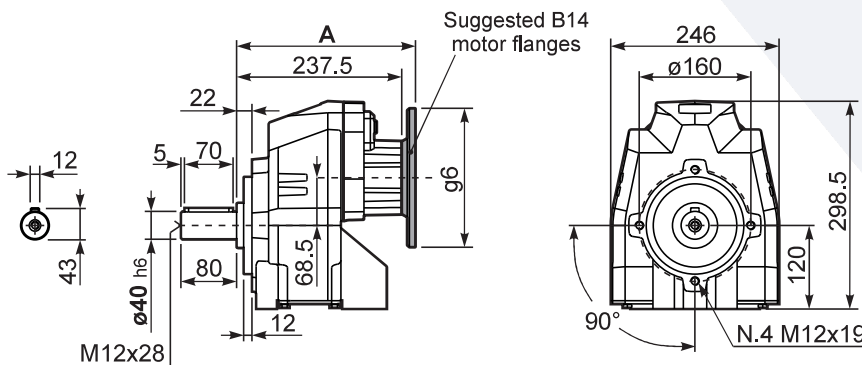

B5 Motor Flanges	A	C _{max}	g6	k1	kit code
71 B5	256	323.5	160	256	K023.4.041
80/90 B5	258	343.5	200	258	K023.4.042
100/112 B5	267	368.5	250	267	K023.4.043
132 B5	285	393.5	300	285	KC50.4.043

B14 Motor Flanges	A	C _{max}	g6	k1	kit code
80 B14	258	303.5	120	258	K085.4.046
90 B14	258	313.5	140	258	K085.4.045
100/112 B14	267	323.5	160	267	K085.4.047
132 B14	285	343.5	200	285	KC50.4.041