

QUICK SELECTION / Selezione veloce

input speed (n_1) = 1400 min⁻¹

Output Speed n_2 [min ⁻¹]	Ratio i	Motor power P_{1M} [kW]	Output torque M_{2M} [Nm]	Service factor $f.s.$	Nominal power P_{1R} [kW]	Nominal torque M_{2R} [Nm]	Available B5 motor flanges		Available B14 motor flanges			Output Shaft 	Ratios code
							-B	-C	-O	-P	-Q		
							63	71	56	63	71		
36.5	38.40	0.37	91	1.9	0.71	175			C	C		171713	02
32.0	43.69	0.37	104	1.4	0.53	149			C	C		191712	03
27.6	50.64	0.37	120	1.3	0.49	160			C	C		171712	04
26.2	53.36	0.37	127	1.1	0.40	138			C	C		191710	05
22.9	61.21	0.37	145	1.1	0.41	160			C	C		191312	06
22.6	61.85	0.37	147	0.9	0.35	138			C	C		171710	07
19.7	70.95	0.37	168	1.0	0.35	160			C	C		131712	08
19.1	73.43	0.37	174	1.0	0.37	175			C	C		101713	09
18.7	74.77	0.25	120	1.2	0.29	138			C	C		191310	10
16.2	86.66	0.25	139	1.0	0.25	138			C	C		131710	11
14.5	96.85	0.25	155	1.0	0.26	160			C	C		101712	12
13.6	102.89	0.25	165	1.1	0.27	180			C	C		101313	13
11.1	126.40	0.18	155	1.0	0.20	160			C	C		91712	17
10.3	135.69	0.18	166	1.0	0.18	160			C	C		101312	15
8.4	165.74	0.12	131	1.1	0.13	138			C	C		101310	16
7.9	177.09	0.12	140	1.1	0.14	160			C	C		91312	18
6.5	216.31	0.09	136	1.0	0.10	138			C	C		91310	19

The dynamic efficiency is **0.94** for all ratios

 **Motor Flanges Available**
Flange Motore Disponibili

 **B) Supplied with Reduction Bushing**
Fornito con Bussola di Riduzione

B) Available on Request without reduction bushing
Disponibile a Richiesta senza Bussola di Riduzione

 **C) Motor Flange Holes Position**
Posizione Fori Flangia Motore







EN Unit **403A** is supplied with synthetic oil for lifetime lubrication, no maintenance is necessary. See table 1 for lubrication and recommended quantity. In table 2 please see possible radial loads and axial loads on the gearbox.

I Il riduttore **403A** viene fornito completo di olio sintetico per la lubrificazione permanente e non necessita di alcuna manutenzione. Vedi tab.1 per oli e quantità consigliati. In tab.2 sono presenti i carichi radiali e assiali applicabili al riduttore.

D Das Getriebe **403A** ist mit synthetischem Öl gefüllt und ist lebensdauergeschmiert. In Tabelle 1 ist die Schmiermenge und das empfohlene Schmiermittel angegeben. In Tabelle 2 sind die zulässigen Radial - und Axialbelastungen des Getriebes aufgeführt.

F Le réducteur **403A** est fourni complet avec de l'huile synthétique pour la lubrification permanente et ne nécessite aucun entretien. Voir tableau 1 concernant les huiles et les quantités conseillées. Les charges radiales et axiales applicables au réducteur sont précisées dans le tableau 2.

E El reductor tamaño **403A** se suministra, lubricado de por vida con aceite sintético y no requieren mantenimiento alguna. Ver tabla 1, para cantidades y aceites recomendados. En la tabla 2, se encuentran las cargas radiales y axiales admitidas por el reductor.

Standard supplied	For these mounting position specify in the order or add oil Per queste posizioni specificare in fase d'ordine o aggiungere olio					
						
0.30 LT	0.35 LT	0.45 LT	0.45 LT	0.45 LT	0.55 LT	Ask
AGIP Telium VSF 320			SHELL Omala S4 WE 320			

For all details on lubrication and plugs check our website **tab. 1**
Per maggiori dettagli su lubrificazione e tappi olio vedi il nostro sito web

RADIAL AND AXIAL LOADS

Output shaft
Albero di uscita

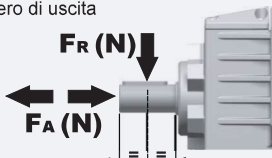

$F_{eq} = F_R \cdot \frac{46}{X+21}$

$F_{eq} (N)$

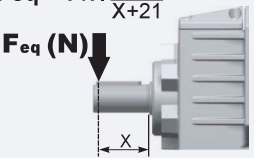

n_2	FA	FR	n_2	FA	FR	n_2	FA	FR
300	310	1550	140	406	2030	70	540	2700
250	330	1650	120	448	2240	40	600	3000
200	360	1800	85	480	2400	15	600	3000

Input shaft
Albero in entrata

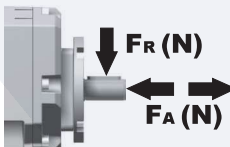

n_1	FA	FR
1400	140	700
900	160	800
500	190	950

tab. 2

P403A-B1 ... With feet
Con piedini

Gearbox weight / peso riduttore: With flange **6.1 kg**, With feet **6.3 kg**

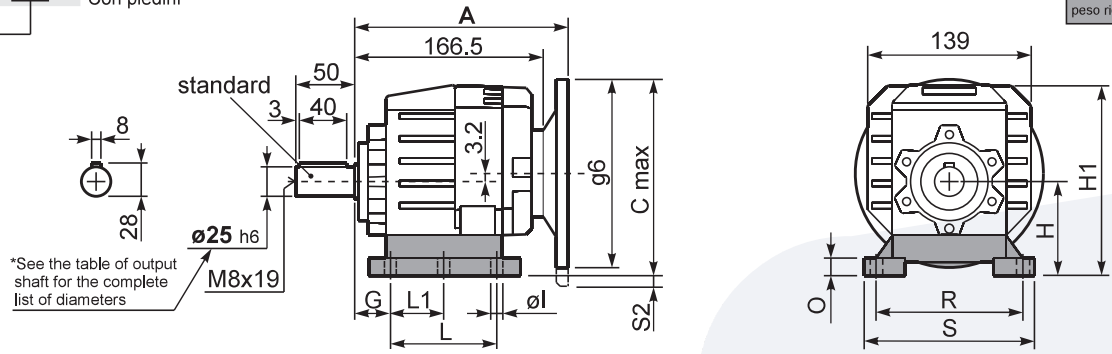

Feet / piedini

Feet Code	Market reference	G	H	R	L	L1	S	H1	O	øl	S2 only with motor flange	B5 max. Flange	kit code
B1	112	18	85	110	87	50	130	167	15	-	-	-	KC35.9.021
B2	212/3	18	100	130	107.5	60	155	182	17	11	-	-	KC40.9.025
S1	17	18	75	110	90+110	50	145	155	15	9	2 80/90B5	-	KC40.9.022
S2	27	25	90	110	130	-	145	172	20	9	-	-	KC40.9.024
H2	022-223	25	100	110	115	-	145	182	20	9	-	-	KC40.9.026
M1	42/3	25	80	110+120	85	-	145	162	15	9	-	-	KC40.9.023
H1	020-221	18	80	110	90	-	135	162	14	9	13 80/90B5	-	KC35.9.022

Other feet are available, please contact Alpathek for information.

A see on page bottom

Most popular types / Tipi più diffusi

P403A-F ... Output flanges
flange di uscita

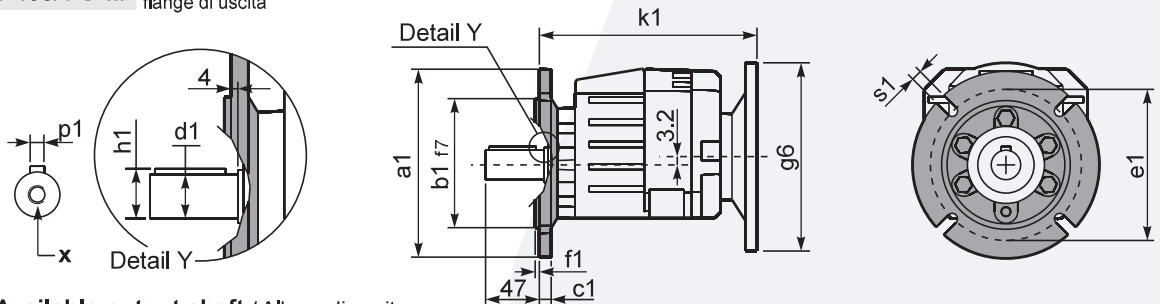

***Available output shaft / Albero di uscita**

	Shaft - d1	p1	h1	x
Standard	ø 25x50	8	28	M8x19
On request A richiesta	ø 16x40	5	18	M6x16
	ø 19x40	6	21.5	M6x16
	ø 20x40	6	22.5	M8x19
	ø 24x50	8	27	M8x19

Available output flanges / flange di uscita

a1 ø	b1	c1	e1	f1	s1	kit code
120	80	10	100	3	7	KC40.9.010
140	95	10	115	3	9	KC40.9.011
160	110	10	130	3.5	9	KC40.9.012
200	130	11	165	3.5	11	KC40.9.013
250	180	11.5	215	3.5	14	KC40.9.014

With flange and feet only on request. Ask for compatibility

P403A-N ... Basic gearbox
Riduttore base

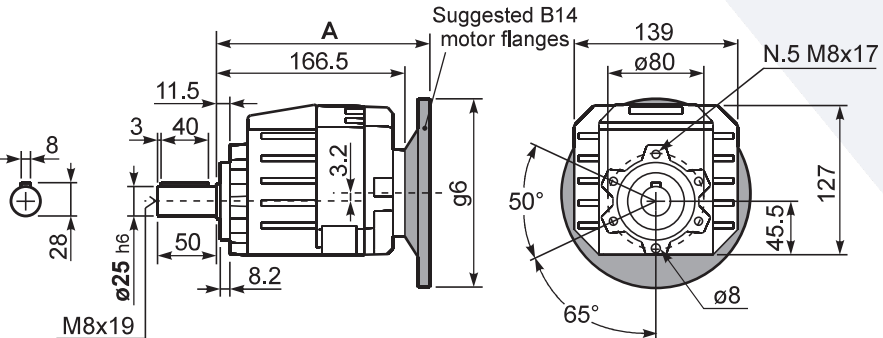

R403A-N ... Input Shaft
Albero in entrata

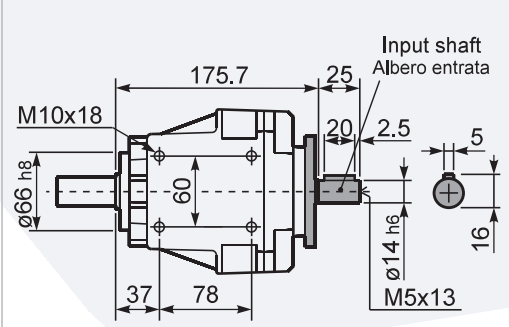

B5 Motor Flanges	A	C _{max}	g6	k1	kit code
63 B5	185	173.2	140	189	K050.4.041
71 B5	182.5	183.2	160	186.5	K050.4.042

B14 Motor Flanges	A	C _{max}	g6	k1	kit code
56 B14	182.5	143.2	80	186.5	KC40.4.049
63 B14	185	148.2	90	189	K050.4.047
71 B14	182.5	155.7	105	186.5	K050.4.045